

CAPITAL UNIVERSITY OF SCIENCE AND
TECHNOLOGY, ISLAMABAD



**Application of STATCOM for the
Mitigation of Disturbance and
Stability of Wind Farm
Connected to Weak Grid**

by

Syed Wahid Shah

A thesis submitted in partial fulfillment for the
degree of Master of Science

in the

Faculty of Engineering

Department of Electrical Engineering

2019

Copyright © 2019 by Syed Wahid Shah

All the rights of this document are held in reserve. If someone wants to copy in a whole or in any part of this document in any form, he/she must need the prior written permission of Syed Wahid Shah or designated representative.

I am dedicating this thesis to my Parents, Family, Friends and Teachers for their
limitless love, care and inspiration.



CERTIFICATE OF APPROVAL

Application of STATCOM for the Mitigation of Disturbance and Stability of Wind Farm Connected to Weak Grid

by

Syed Wahid Shah

(MEE-161012)

THESIS EXAMINING COMMITTEE

S. No.	Examiner	Name	Organization
(a)	External Examiner	Dr. Babar Hussain	PIEAS, Islamabad
(b)	Internal Examiner	Dr. Muhammad Ashraf	CUST, Islamabad
(c)	Supervisor	Dr. Umer Amir Khan	CUST, Islamabad

Dr. Umer Amir Khan

Thesis Supervisor

July, 2019

Dr. Noor Muhammad Khan
Head
Dept. of Electrical Engineering
July, 2019

Dr. Imtiaz Ahmed Taj
Dean
Faculty of Engineering
July, 2019

Author's Declaration

I, **Syed Wahid Shah** here by state that my MS thesis titled “**Application of STATCOM for the Mitigation of Disturbance and Stability of Wind Farm Connected to Weak Grid**” is my own work and has not been submitted previously by me for taking any degree from Capital University of Science and Technology, Islamabad or anywhere else in the country/abroad.

At any time if my statement is found to be incorrect even after my graduation, the University has the right to withdraw my MS Degree.

Syed Wahid Shah

(MEE-161012)

Plagiarism Undertaking

I solemnly declare that research work presented in this thesis titled “*Application of STATCOM for the Mitigation of Disturbance and Stability of Wind Farm Connected to Weak Grid*” is solely my research work with no significant contribution from any other person. Small contribution/help wherever taken has been dully acknowledged and that complete thesis has been written by me.

I understand the zero tolerance policy of the HEC and Capital University of Science and Technology towards plagiarism. Therefore, I as an author of the above titled thesis declare that no portion of my thesis has been plagiarized and any material used as reference is properly referred/cited.

I undertake that if I am found guilty of any formal plagiarism in the above titled thesis even after award of MS Degree, the University reserves the right to withdraw/revoke my MS degree and that HEC and the University have the right to publish my name on the HEC/University website on which names of students are placed who submitted plagiarized work.

Syed Wahid Shah

(MEE-161012)

Acknowledgements

I wish to solemnly express my sincere gratitude and deep appreciation to my supervisor **Dr. Umer Amir Khan** at this time for their constant guidance, encouragement and support throughout the whole program. A new window is open for me in Electrical Engineering with their direction, from which I greatly broadened my horizon in the application of power electronics and hence my professional career has benefited tremendously from the exciting learning procedure. My foremost thanks go to him and I also wish to extend my appreciation to other professors and support staff in the Department of Electrical Engineering for their help during my study here.

I also wish to thank to my brothers and some of my friends for their continuous support and constructive suggestions that inspired and motivated me to complete the study, without whom I would be unable to finish my project successfully.

Syed Wahid Shah

(MEE-161012)

Abstract

This thesis describes the impact of Static Synchronous Compensator (STATCOM) on stability of the wind farms based on double fed induction generators (DFIG) and fixed speed induction generators (FSIG) which are connected to power system, after a severe disturbance occurrence. Because of asynchronous characteristic of fixed speed induction generators, the instability in wind farms based on FSIG is severally created by the extreme reactive power absorption by FSIG after fault. This phenomenon is a result of rotor slip of FSIG increase during the fault, and during steady state condition when the induction generator operates, it has variation in slip and speed. So during no load condition and slip is near to zero, less reactive power absorbed by machine but when the load and power generation is increased, results in the rotor slip and the reactive power absorption rises. The reactive power is mainly compensated per turbine level in the wind farms i.e., when the power output is increased, a number of power factor capacitor (PFC) are gradually connected to induction generator terminal through mechanical switches. However, this system can only generate steady state compensation and cannot be an effective compensating tool during transient conditions. During normal operation, the electric torque is equal to the mechanical torque and the FSIG is in steady state condition. When a system fault happens, a sudden drop in the AC voltage is created and it causes the FSIGs electrical torque reduction and consequently, the consumption of reactive power is raised. So the performance of the wind farm equipped by STATCOM to improve the wind farm stability during and after fault.

This thesis discusses the problems and implications of wind integration in the network. As a corrective measure, the application of the Static Synchronous Compensator (STATCOM) will be investigated to improve the dynamics of the hybrid wind farm DFIG and FSIG connected to the grid. The STATCOM control strategy has been developed to improve the stability of dynamic wind turbine power. STATCOM provides voltage support by providing or receiving reactive power in the event of fault. The simulation results show that STATCOM can enhance the

system stability during and after disturbance, especially when the network is weak.

Contents

Author’s Declaration	iv
Plagiarism Undertaking	v
Acknowledgements	vi
Abstract	vii
List of Figures	xi
List of Tables	xiii
List of Abbreviations	xiv
1 Introduction	1
1.1 Background	1
1.2 Recent Technologies and Control in Wind Turbine	2
1.2.1 Technologies in Wind Turbine	3
1.2.1.1 Fixed-Speed Wind-Turbine Technology	4
1.2.1.2 Double Fed Induction Generator Wind Turbine Technology	4
1.2.1.3 PMSG Variable Speed Wind turbine	6
1.3 Voltage and Wind Farm Connectivity	8
1.4 Methods of Reactive Power Compensation	8
1.4.1 Synchronous Condenser	8
1.4.2 Static VAR Compensator (SVC)	9
1.4.3 Static Synchronous Compensator (STATCOM)	9
1.5 Objective	10
1.6 Thesis Overview	11
2 Literature Review and Problem Formulation	12
2.1 Literature Review	12
2.2 Gap Analysis	14
2.3 Problem Statement	15

3	System Modeling	17
3.1	Weak Grid	17
3.2	STATCOM	19
3.2.1	Modeling of STATCOM	22
3.2.2	Transformation to dq Frame from abc Frame	25
3.2.3	Modeling of STATCOM Connected to a Grid	27
3.2.4	Basic STATCOM Controller	29
3.2.5	Phase Locked Loop (PLL)	30
3.2.6	Real and Reactive Power Control from VSI	30
3.3	Modeling of Wind Energy System	31
3.3.1	Source of Wind and Characteristics Properties	31
3.4	Modeling of Wind Turbine	32
3.4.1	Power in Wind	32
3.5	Modeling of Wind Turbine Connected with Weak Grid	33
3.5.1	Single Wind Turbine Simulation using MATLAB/ SIMULINK	33
3.5.2	Multiple Wind Farm Connected with Weak Grid	35
4	Simulation Results	37
4.1	Simulation of Wind Turbine Connected to Weak Grid	40
4.2	Simulation of Weak Grid with Fault	40
4.3	Behavior of Grid with Fault and STATCOM	45
5	Conclusion and Future Work	51
5.1	Conclusion	51
5.2	Future Work	52
	Bibliography	54

List of Figures

1.1	Global Capacity of Wind Power (2000-2013) [1]	3
1.2	Worldwide capacity and addition wind power, Top countries [1]	4
1.3	Fixed speed with induction generator [3]	5
1.4	Double Fed Induction Generator (DFIG) [7]	6
1.5	Self excited induction generator (SEIG) [9]	6
1.6	Variable Speed Gear-Driven Wind Turbines [8]	7
1.7	Wind Turbine PMSG [11]	8
1.8	Static VAR compensator [18]	10
1.9	Static synchronous compensator (STATCOM)[18]	11
3.1	Simulink Model of Weak Grid	18
3.2	Source block model	19
3.3	Source Block Parameter	20
3.4	Functional model of STATCOM [9]	20
3.5	STATCOM Power exchange [9]	21
3.6	Equivalent Circuit of STATCOM [9]	22
3.7	STATCOM Simulink Model	23
3.8	Internal Structure of STATCOM Simulink Model	23
3.9	Block Parameter of STATCOM Simulink Model	24
3.10	Controller of STATCOM Simulink Model	24
3.11	Three-phase electric variable in vector form [19]	26
3.12	Three phase electrical variable (abc) and (dq) frame [26]	27
3.13	Schematic diagram of STATCOM connected to Grid [26]	27
3.14	Basic STATCOM Controller block diagram [26]	29
3.15	Phase Locked Loop (PLL) block diagram [26]	30
3.16	Mass 'm' of Air flows through an Area A [28]	33
3.17	Wind Turbine connected with Weak Grid without STATCOM	34
3.18	Wind Turbine connected to Weak Grid with STATCOM	34
3.19	Turbine With Fault	35
4.1	Complete System Model	38
4.2	Data Acquisition description circuit wind farm	39
4.3	25kV Bus Data Acquisition Circuit	39
4.4	Parameters of Weak Grid	40
4.5	Active Power Turbine1	41
4.6	Reactive Power Turbine1	42

4.7	Active and Reactive Power Turbine2	42
4.8	Active Power Turbine3	43
4.9	Reactive Power Wind Turbine3	44
4.10	Rotor Speed Wind Turbine3	44
4.11	Voltages Bus Line25(pu)	45
4.12	Rotor Speed of Wind Turbine3	46
4.13	Voltage Bus Line	47
4.14	Active and Reactive Power of Wind Turbine3	48
4.15	STATCOM Vm(pu)	49
4.16	STATCOM Generated Q(MVar)	49

List of Tables

3.1	System Model Values	36
3.2	9MW induction wind turbine model parameters	36

List of Abbreviations

A	cross-sectional area through which the wind passes
AC	Alternate Current
C	DC-link Capacitance
C_p	power coefficient
DC	Direct Current
FACTS	Flexible AC Transmission Systems
I_a, I_b , I_c	Line output currents of the power inverter
I_d	d-axis current
IGBT	Insulated-Gate Bipolar Transistor
I_q	q-axis current
J	inertia
LV	Low Voltage
M	mutual inductance
MV	Medium Voltage
N_s	stator windings turn number
P	the operator d/dt
PT	Turbine power
P_{wind}	power in the wind
Q_g	reactive power
R	the radius of the turbine
R_f	line resistance
R_s	stator resistance
S	per phase complex power
SGs	Synchronous generators

Vdc	DC-link voltage
VSC	Voltage Source Converter

Chapter 1

Introduction

1.1 Background

Current development in wind energy shows that it will play a leading role in meeting the energy target in the future and will also reduce dependence on fossil fuel. Among renewable sources, wind power is the fastest growing technology. Global capacity of wind energy has increased in the last decade and is a challenge for traditional sources of energy. Figure 1.1[1] and Figure 1.2 [1] shows that in 2013, the wind power capacity of more than 35 GW was merged to the capacity of global wind power generation, which becomes 318 GW. The capacity of wind energy according to cumulative annual growth rates has averaged 21.4% since 2018 [1].

Due to competition and advancement in technology, which include long blades, tall towers and small generators in the low speed area, they now have higher capacity factors [1]. Then, as a result, the capital cost of wind generation technologies has been reduced. Compared to the generation based on fossil fuels, the development of aggregate technology to minimize the costs of wind turbines and the competition with fossil fuel, makes it even more reliable. Based on kilowatt-hours with new gas and coal power plants in numerous markets. The generation of wind energy now has a reasonable cost. As development of power generation, a high

level of wind energy of less than 30% will be included in the network, but many problems and challenges will arise that must be mentioned for reliable operation of the current energy system [2].

In the coming decades, the addition of wind increases, so the structure and dynamics of the energy system will be modified accordingly. As a replacement for synchronous generators based on electronic power converters over traditional synchronous generators, some special challenges will be presented in the interconnections of the network, that is, bidirectional power control, frequency regulation, low voltage, dynamic stability and protection [3]. Therefore, for a better operation of the energy system, the probable effects of large-scale wind integration to energy are mandatory to confirm the consistency.

1.2 Recent Technologies and Control in Wind Turbine

Due to advance structure of turbines and the controlled topologies based on electronics in the last decades. Wind energy is now become the most encouraging technology in renewable energy.

Wind industries are moving forward to improve the efficiency and control capacity of variable-speed turbines and to increase the comprehensive integration of the wind turbine. The recent development shows an increase in wind farms and has participate significantly in energy production sharing and will go to new challenges and problems in the control and operations of the electrical system. This includes the addition to the weak regulation of the network, the frequency and the voltage, the disturbance of the dynamic stability of the voltage, the fluctuations of the power and the changing in conventional power plants [3]. For wind power plants, it is necessary to comply with these requirements for reluctant and stable operation of the new power supply system. Currently, DFIG is powered by variable speed gearboxes in the market, there is however progress for a non-PMSG gearbox with

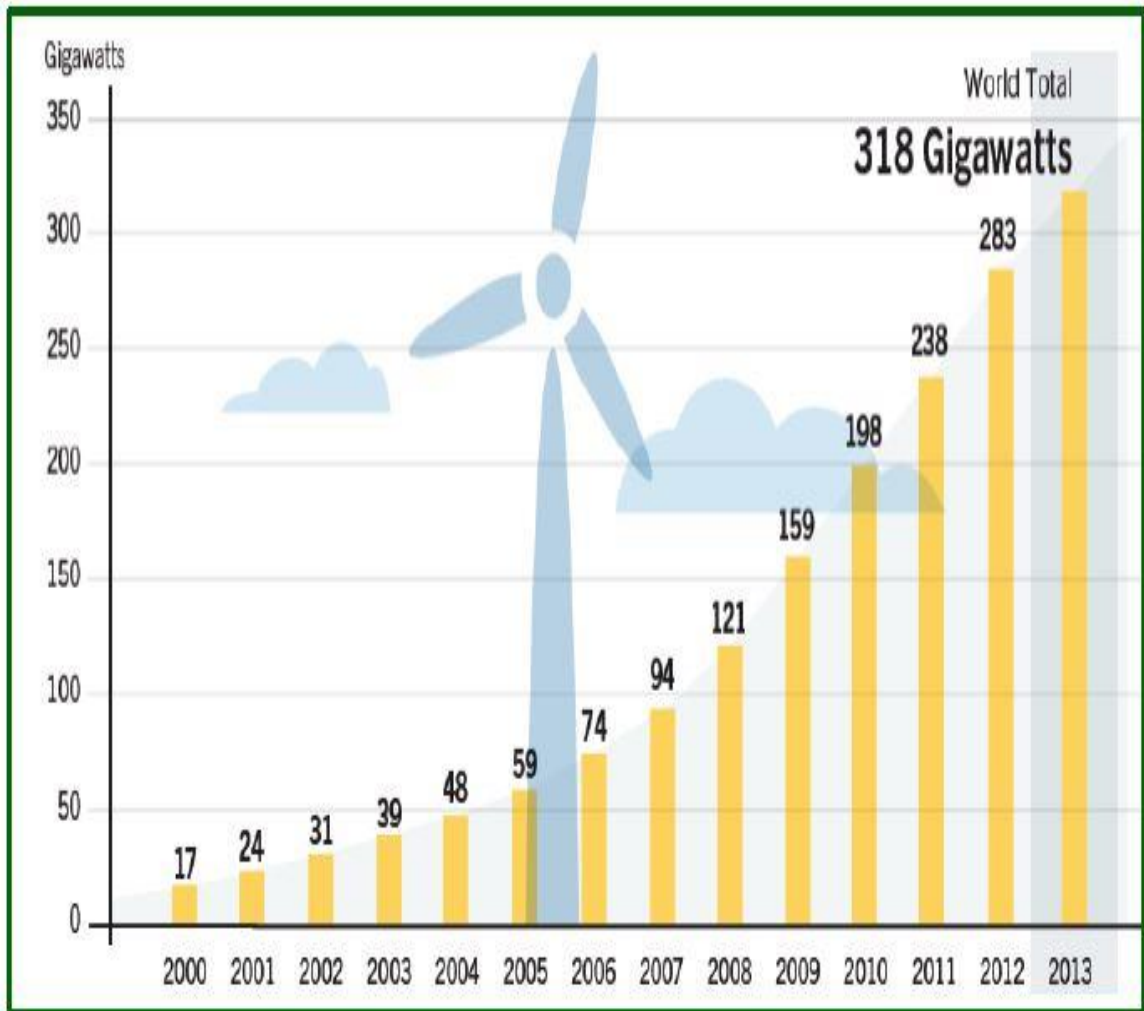

FIGURE 1.1: Global Capacity of Wind Power (2000-2013) [1]

a variable speed turbine for higher efficiency, performance, lower maintenance, smaller size and better offset of defects across the competition [4].

1.2.1 Technologies in Wind Turbine

Some of wind turbine technologies are as under:

1.2.1.1 Fixed-Speed Wind-Turbine Technology

The fixed speed wind turbine is shown in Figure 1.3 [3]. It is directly connected to the grid uses the induction generator (SCIG) in the cabinet via a clutch transformer. A capacitor battery is required because the problems associated with the induction generator are consumption of reactive power, poor energy quality and mechanical stress [4]. The fluctuations FSIG turbine are transmitted in mechanical torque as fluctuations and cause electric power fluctuations. The fluctuations in power can lead to strong voltage fluctuations in the weak network [5].

1.2.1.2 Double Fed Induction Generator Wind Turbine Technology

At present, DFIG wind turbines are famous because of their advantages, i.e. maximizing power, achieving higher energy, best energy quality and high efficiency [6]. The advantage of this technology is that a low capacity converter (30% of the total capacity) is required because instead of stator, the drive is directly connected to

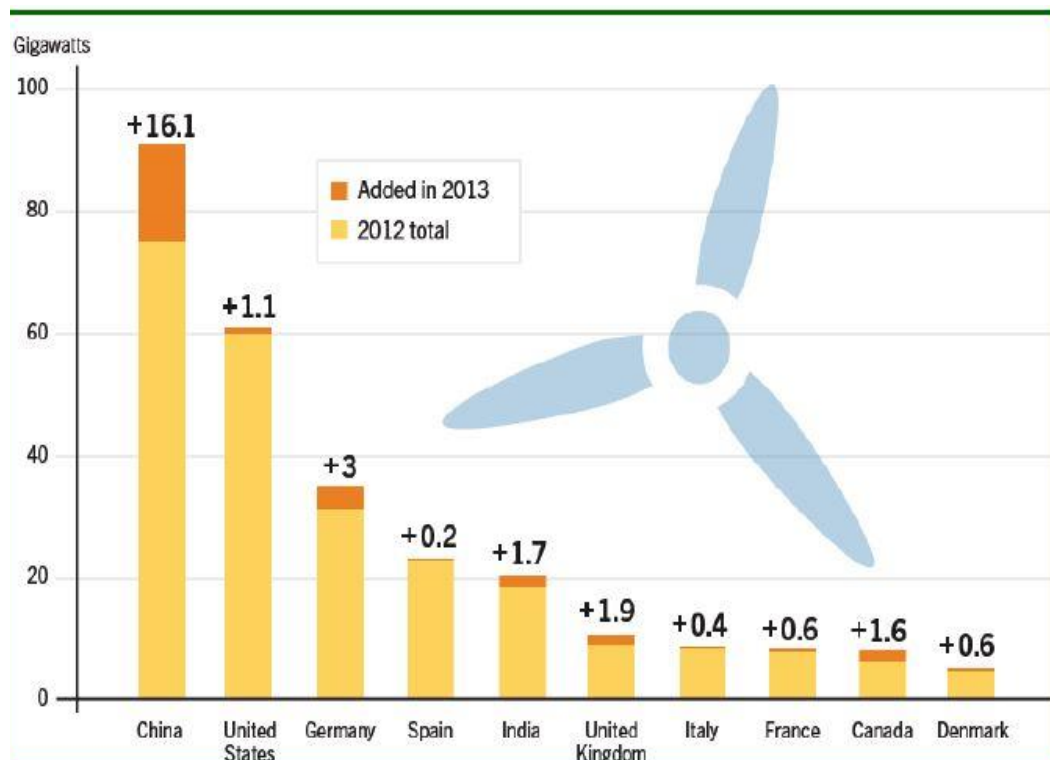

FIGURE 1.2: Worldwide capacity and addition wind power, Top countries [1]

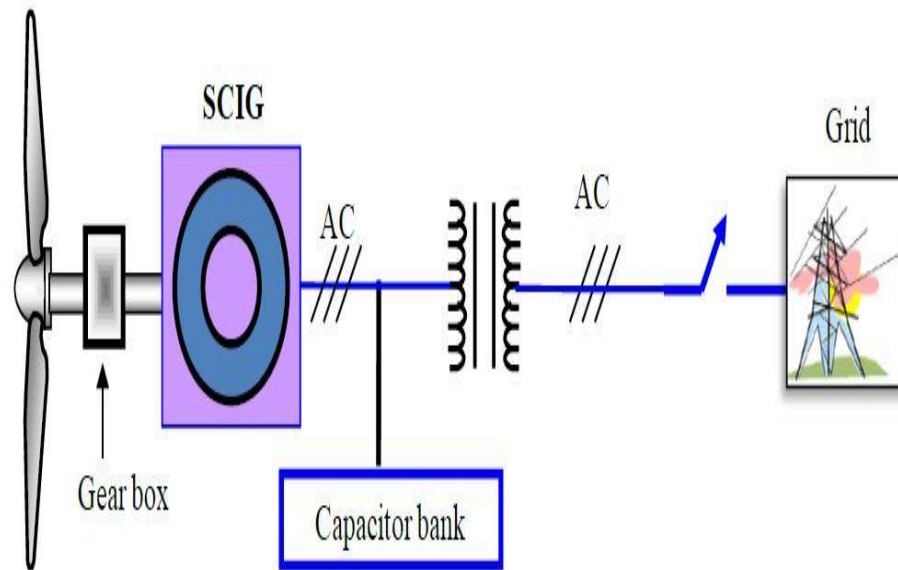

FIGURE 1.3: Fixed speed with induction generator [3]

the rotor.

In DFIG configuration, rotor is connected to a network via a voltage converter and stator is connected directly to the rotor speed control network and its frequency Figure 1.4 [7]. DFIG technology can operate at a wide speed range, which depends on the size of the drive. In general, the range of variable speeds is approximately 30% around the synchronous speed, making them attractive, economically [8]. As soon as the generator moves at a supersonic speed, power is fed into the grid through stator and rotor while generator moves synchronously with the grid rotor [3]. Synchronous winding rotor generator and self-excited with induction generator are driven by variable speed wind turbines as shown in Figure 1.5 [9] and Figure 1.6 [8] respectively.

Disadvantage of this wind turbine, however, is the need for a gearbox that needs regular maintenance and because it is made of faults. The overall size of the wind turbine is also increases. Second disadvantage of the DFIG wind energy plant is the voltage drop, since it is very sensitive to network interference, since the stator is connected directly to the network. In addition, overvoltage can be caused by voltage drop and the voltage drops also causes overcurrent in the rotor winding, which damages the rotor side converter.

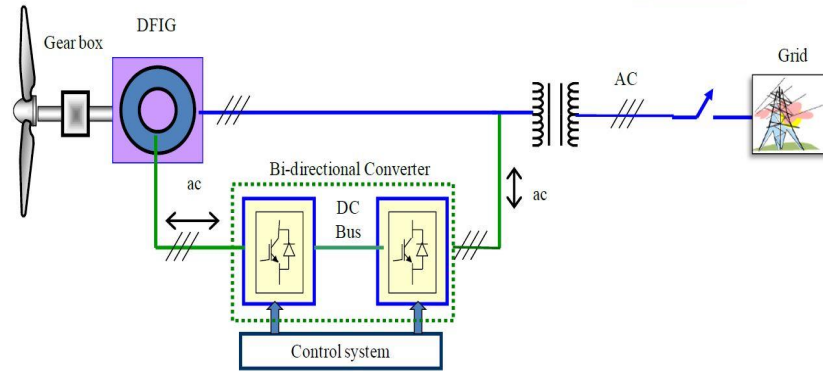

FIGURE 1.4: Double Fed Induction Generator (DFIG) [7]

The wind power plants and the power transducer must have the capability of protecting themselves without disconnecting during failures to provide a good disturbance path (FRT) DFIG. To avoid the converter short-circuiting the rotor windings, a lever is needed. Present an extra protection for this purpose [10].

1.2.1.3 PMSG Variable Speed Wind turbine

In PMSG the turbine rotor without transmission line is connected directly to the generator rotor with the AC-DC-AC converter, and the generator is connected to the grid Figure 1.7 [11]. For total control of the power, this configuration is the most appropriate, since it is connected to the network with the help of a power

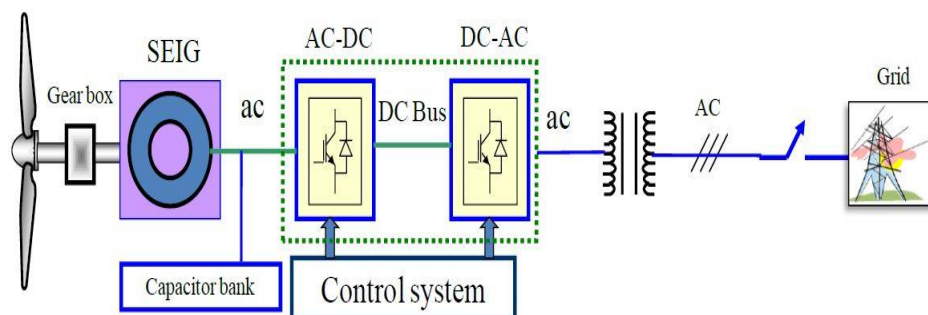

FIGURE 1.5: Self excited induction generator (SEIG) [9]

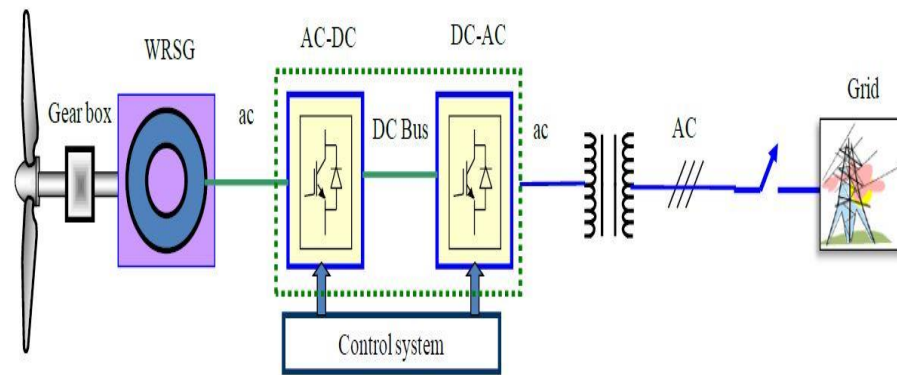

FIGURE 1.6: Variable Speed Gear-Driven Wind Turbines [8]

converter. This configuration uses synthetic PMSG generators, which are low-speed generators with a good number of poles and at low speeds create a high torque. Throughout the speed range, the full-scale power converter can run a network connection without faults [11].

The two main objectives of the electronic power converters are:

1. It acts as a power cache (DC-link) for power fluctuations.
2. Ensure that admission is temporary on the network side and also controls active and reactive system performance.

The main features of wind turbine PMSG are:

- o Operation without gears and greater reliability.
- o Smaller size, simpler structure and lower cost of PMSG.
- o Reduced electrical and mechanical losses.
- o Good efficiency and maximum power factor.
- o No request to support reactive power.
- o In converters, higher costs and power losses.
- o There is no external excitation requirement.

In comparison with the DFIG system, the PMSG has a good capacity for fault handling because the PMSG has low complexity and better efficiency.

1.3 Voltage and Wind Farm Connectivity

Whenever a strong wind flow occurs, wind farms generate energy [12]. During the night, the loads of the clients diminish; reason why the generation of a great amount of wind energy during the nocturnal hours causes that the excess of power flows in opposite sense towards the network. This back flow of energy increases line voltage beyond the limit set by the tools [13], which results in a reduction in wind energy that can be transmitted over the line. Therefore, the installation of the voltage control mechanism allows greater connectivity of the wind farms.

1.4 Methods of Reactive Power Compensation

1.4.1 Synchronous Condenser

It is a synchronous motor that operates without load, so for voltage regulation and power factor correction the synchronous condenser can provide variable reactive power.

This was the first device to provide dynamic support for reactive energy. It has a slow reaction velocity due to the large inertia of rotating mechanical parts (rotors)

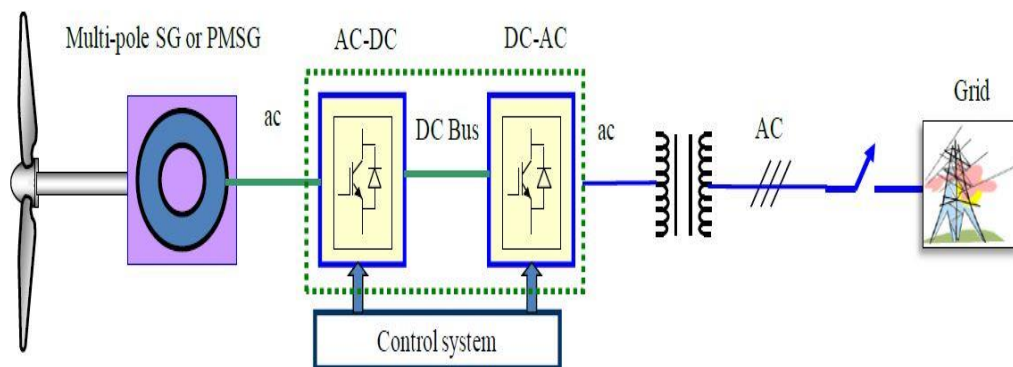

FIGURE 1.7: Wind Turbine PMSG [11]

that occupy 300 ms to 500 ms to compensate for dynamic reactive power [14]. The synchronous condenser does not require a physical component like inductor or capacitor, so it does not generate harmonics. It is still used and installed worldwide.

1.4.2 Static VAR Compensator (SVC)

In advancement of power electronics, FACTS as SVC [15], [16], [17] were used to dynamically compensate reactive power. These devices are fixed and do not contain rotating components, such as a synchronous condenser. Thanks to its robust nature and the use of electronic switches, SVC provides faster response than a synchronous condenser.

It consists of a capacitor coupled to a mechanical switch and an inductor in series with thyristor switches connected in parallel Figure 1.8 [18]. The device is connected to a high voltage line (HV) with a transformer to reduce the rated voltage of the thyristor valves [15].

To provide a reactive power, the capacitor connects to the network and to achieve dynamic support, the thyristor valves change their current induction force. Working together, the SVC functions as a variable capacitor or variable inductor.

1.4.3 Static Synchronous Compensator (STATCOM)

STATCOM FACTS is a sophisticated device that does not support physical induction or reactive power unlike SVC. STATCOM offers a reactive power through interaction of the potential reactive interactions of the AC phase.

STATCOM uses IGCT, IGBT or GTO as a switching device. Both ON and OFF events are controlled on drivers. As a result, it gives two degree of freedom compared to SVC's thyristors. It has more control and efficiency. The typical STATCOM connected to the medium voltage bus (MV). The TR transformer is used to reduce the voltage and harmonics of the high voltage bus (HV) so that the

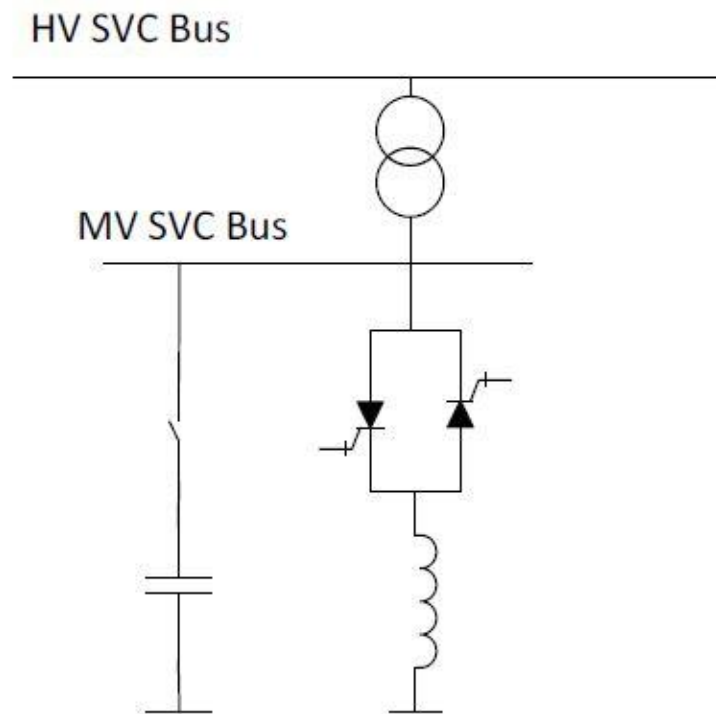

FIGURE 1.8: Static VAR compensator [18]

lowest voltage (S1-S6) can be used. It has a DC current capacitor that provides a current path [15]. The STATCOM operating time ranges from 15 to 30 ms, which is very fast in all FACTS devices. The absence of rotational weight and the use of IGCT, GTO or IGBT as a switching device are the main reasons for its rapid response. This explains the name Synchronous Static Compensator (STATCOM) Figure 1.9 [18].

1.5 Objective

The objective of this study is to review previous publications and conduct a comprehensive review of wind turbines and STATCOM. Then the complete modeling of the FSIG wind turbine connected with STATCOM is discussed. And, finally,

simulate the derivative model using MATLAB-Simulink to determine the performance parameters of model implemented.

1.6 Thesis Overview

This thesis composed of five chapters including introduction, which includes the overview of different systems and their basics, background and the objective of study. Second chapter presents the literature review and the third chapter is System Modeling. Chapter four discussed the results and finally chapter five is conclusion and future work.

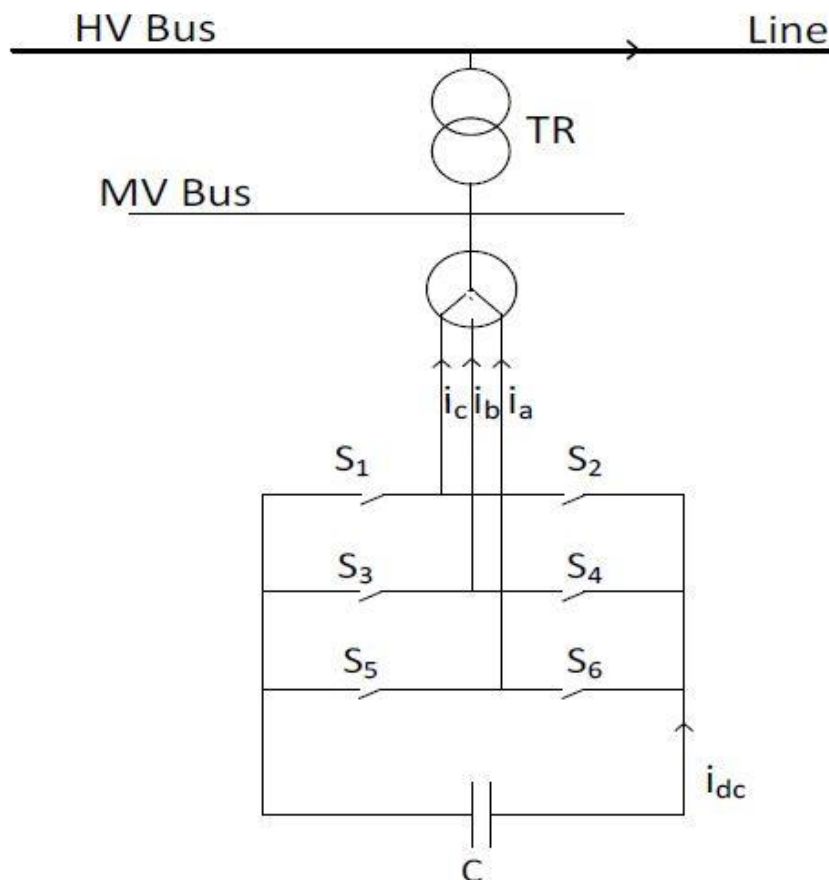

FIGURE 1.9: Static synchronous compensator (STATCOM)[18]

Chapter 2

Literature Review and Problem Formulation

This chapter presents detail overview of the literature, gap analysis and problem statement and methodology are also discussed in this chapter.

2.1 Literature Review

In recent years, the use of energy production and transmission has been severely restricted due to resource constraints and environmental constraints; on the other hand, the demand for energy has increased. As a result, transmission lines are heavily loaded and affect the stability of the system. For this purpose, Flexible Transmission Systems (FACTS) have been used to provide sufficient solutions for the various stationary problems of energy systems. Recent research also shows that FACTS can be used to increase the stability of the electrical system.

Literature shows growing interest in the subject over the past two decades, where the system's stability improvements are being carried out using FACTS and has been thoroughly explored. This thesis describes system stability, voltage drops, and reactive energy problems solved by FACTS, such as STATCOM.

The Static Sync Compensator (STATCOM) is a type of FACTS device that is similar to synchronous condenser, used to control voltage and reactive power compensation. STATCOM increases transmission capacity, reduce low frequency oscillation and improve transition stability. The paper [19] discusses the STATCOM control block diagram to improve transient stability. SIMULINK software is used to simulate the system.

It is a device that can control the flow of energy through the line by injecting reactive power into the power system. The paper [19] analyzes the instability of the power system and also the importance of rapid troubleshooting for reliable power generation. Transient stability, including synchronization and damping pairs, is assumed.

The stability of the wind farm is one of the indices in which the researcher thinks, and many researches have been conducted on various methods that have analyzed and improved the stability of the wind farm [20]. In [21], wind turbine-based the FSIG stability is analyzed with the same area as previously established for generators. Moreover, having different features of the FSIG synchronous generator, this method is not an acceptable analysis. In [20], it is suggested that resistance to rupture when absorbing active power during a failure to improve system stability, but an important issue for FSIG is to provide reactive power during and after fault and this technique is not effective. In [9], it is recommended to improve wind stability FACTS devices be used such as SVC and STATCOM. Stability in general allows the electrical system's ability to synchronize when transitory interferences are serious, for example, device failure and transmission line, or general creation or loss of charges.

In paper [20], STATCOM connects to 230kV line with a typical two-way transmission system. According to the study, STATCOM does not significantly improve the transient season, but also compensates for real-time reactive power.

In general, generators are synchronous in large power systems, so it is important to maintain synchronization with the network and provide consumers with a standard service. Failure in the power supply system is caused mainly by sudden change in load, faults and loss of excitation. Due to merges of damping in the

power system without any additional costs, the output power of the FACTS devices such as STATCOM and SSSC, which are already compensated in the power supply system, is used. The system output is modulated so that the oscillation of the system is reduced and thus stability is improved [22].

In this paper [3], the problem of voltage instability occurs in an energy system that can not provide reactive energy for failures such as disturbances, heavy loads and swelling and voltage drops. This problem is more serious in the weak network. Therefore, a FSIG or DFIG connected to a weak grid requires a noise mitigation system that improves wind stability in the wind farm. Dynamic reactive power compensator that uses STATCOM at a common point of connection (PCC) is a viable option to minimize the effects of network failures in a wind farm. In this document [23], a fault in the power supply system causes a voltage drop at the point where the wind turbine is connected.

2.2 Gap Analysis

The stability of the FISG [19] of the wind turbines is analyzed in the first field that was incorporated into the synchronous generators. However, due to the different features of the FSIG synchronous generator, this method is not an acceptable analysis.

In paper [9] proposed resistance to rupture when absorbing active power during a malfunction to improve system stability but an important issue for FSIG is to provide reactive power during and after failure and this technique is not effective. In [24] it is recommended to use FACTS as a SVC to improve wind farm stability. Stability in general is the ability of the energy system to survive, in the event of severe interference, such as device failure and transmission line or loss of generalized generation or load, but for a slow SVC response, rapid response to a fast device like STATCOM is required.

In this paper [3], the problem of voltage instability occurs in an energy system that can not provide reactive energy for failures such as disturbances, heavy loads

and swelling and voltage drops. This problem is more serious in the weak network. In paper [22], The proposed reactive power compensation doesn't considered any faults and voltage dips. It is important that faults may be considered in the technique to avoid instability in the system. In paper [25], it is observed that the study has been conducted only with SVC. As the SVC has slower response time than STATCOM then it is considered a gap in reactive power compensation in wind turbine FSIG.

2.3 Problem Statement

When in normal steady state the induction generator operates, it has a small slip and velocity fluctuations. Under no load conditions, when the slip is near zero, the reactive force absorbed by the machine is the lowest value, but increasing the load and power also increases the rotor slip and reactive power absorption.

In wind turbines, reactive power is compensated for mostly by the turbine level, i.e. when power is increased, a number of PFCs are sequentially connected to the inductor generator by mechanical switches. However, this system can produce alignment in a steady state and Can't be good method during transient condition. During normal condition, the electrical torque corresponds to the mechanical torque and the FSIG is in a stable condition. If the system fails, the AC voltage drops suddenly and the FSIG electric torque decreases. Mechanical and electrical torque is unbalanced due to the fixed mechanical torque in this state and this causes the rotor to accelerate and the rotor slip to increase.

To solve these problems, it is therefore necessary to develop a reliable and effective control strategy for FSIG. With increased penetration of the wind into the grid, efficient and reliable wind turbine control is very important. In addition, large wind turbines pose a problem of stability and control. Therefore, a thorough investigation is needed to identify and mitigate potential problems. The integration of wind energy into the existing transmission system requires no significant redesign; it requires additional control and compensation devices that can resolve serious system failures. In this thesis, the use of a static synchronic compensator

(STATCOM) together with wind power plants is investigated to stabilize network voltage after network faults, to improve stability, to reduce power oscillations, to regulate voltage and to increase power transmission and most importantly, regulate reactive power to accelerate the recovery of the voltage after failure.

This thesis discusses the problems and implementations of wind integration in the network. As a corrective measure, the application of the Synchronous Static Compensator (STATCOM) will be investigated to improve the dynamics of the wind farm connected to the grid. The STATCOM control strategy has been developed to improve the stability of dynamic wind turbine power. STATCOM provides voltage support by providing or receiving reactive power in the event of fault.

Chapter 3

System Modeling

This chapter focuses on detail modeling of the system mainly consist of the following parts.

- (i) Weak Grid
- (ii) STATCOM controller
- (iii) Wind Turbine

First introduction of weak grid and its parameter is discussed. In second part introduction of STATCOM and its parts are discussed and in third part wind turbine and its parameters are discussed.

3.1 Weak Grid

In general, Weak Grid means that they have less power capacity and can not provide enough power for the connected load. This means that the voltage level in the weak network is not constant, as in a rigid network, therefore, the impedance of the network is important and must be taken into account. It is more affected compared to the rigid grid if there are faults in the system. Grid can be represented by different parameters. Below its voltage level and power capability, the short circuit SCC can be define as in case of short circuit the amount of power flowing

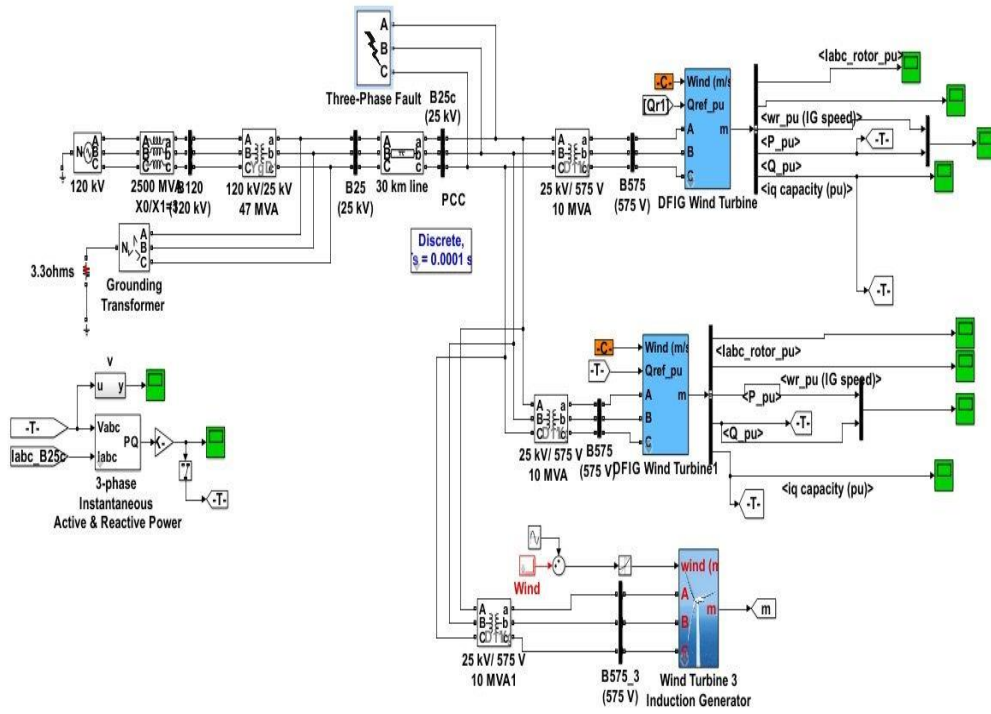

FIGURE 3.1: Simulink Model of Weak Grid

at a given point. It mainly depends on rated voltage U_g and the absolute value of grid impedance Z_{grid} . By definition, the network impedance is the sum of the impedances of many network components and differs mainly from point to point. Transformers are used to connect lines with different voltage levels and they are typically high inductive. If load such as wind turbine with rated power of S_n , wind turbine (WT) is connected to grid, a short circuit ratio SCR can be defined as [1].

$$SCR = \frac{\text{shortcircuitcapacity}}{\text{ratedpower}} \quad (3.1)$$

$$SCR = \frac{SCC}{S_n, WT} \quad (3.2)$$

Besides SCR another important factor to characterize the grid is X/R (ohmic and reactive) ratio. For weak system typically SCR value is less than 20 and X/R ratio is less than 5 [3]. With the values of impedance (Z) and X/R (xrr) ratio the inductive amount X and the ohmic amount of the grid impedance can be calculated as [1].

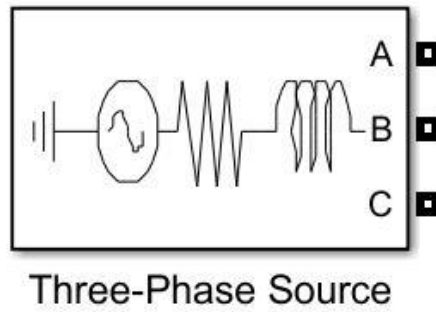

FIGURE 3.2: Source block model

$$X = \frac{Z}{\sqrt{1 + \frac{1}{(X/R)^2}}} \quad (3.3)$$

$$R = \frac{Z}{\sqrt{1 + (X/R)^2}} \quad (3.4)$$

The simulink model of system consists of source block, three phase measurement block, transformer and wind turbine. The following figure shows the Source block model.

The source model contains source parameters. The block parameters is shown in Figure 3.3:

3.2 STATCOM

STATCOM is a source of controlled reactive power, which provides desirable generation and absorption of reactive power. This is done by electronically processing the voltage and current waveforms in the voltage source converter (VSC). The function model of STATCOM is shown in Figure 3.4.

The VSC is connected to the supply bus voltage via a bypass transformer. V_{ac} stands for the bus voltage, I_{ac} is the current fed to STATCOM, V_{out} is the output, V_{dc} and I_{dc} are at DC capacitor side. Drive operation is performed with IGBT drive. The transducer is carried out when diodes lead.

The change in the reactive power between the AC bus line and the inverter can

Three-Phase Source (mask) (link)
 Three-phase voltage source in series with RL branch.

Parameters **Load Flow**

Configuration: Yg

Source

Specify internal voltages for each phase

Phase-to-phase voltage (Vrms): 132e3

Phase angle of phase A (degrees): 0

Frequency (Hz): 50

Impedance

Internal Specify short-circuit level parameters

3-phase short-circuit level at base voltage(VA): 9e6

Base voltage (Vrms ph-ph): 132e3

X/R ratio: 4

FIGURE 3.3: Source Block Parameter

be controlled by changing the amplitude of the three-phase output voltage V_{out} of the converter.

The current flows through the converter's reactance to the AC system as the

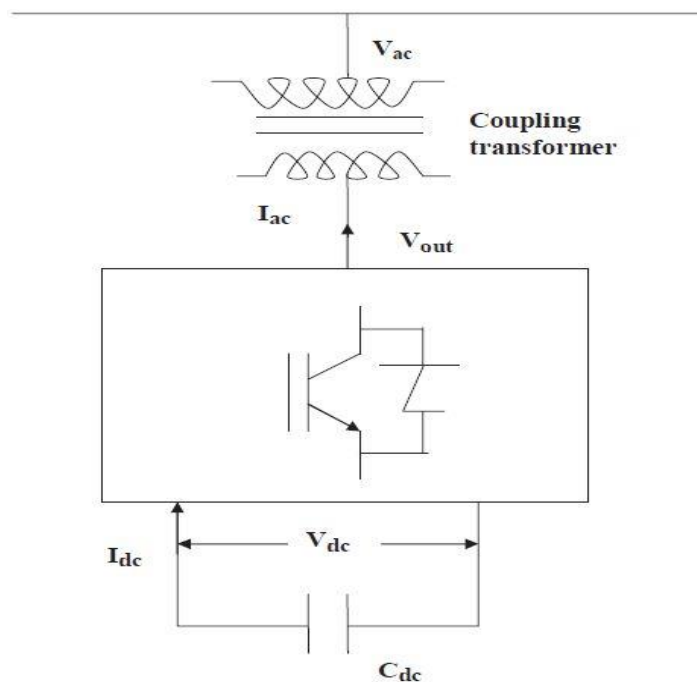

FIGURE 3.4: Functional model of STATCOM [9]

amplitude of V_{out} rise above the voltage of the service bus V_{ac} . In this way, the inverter generates capacitive reactive power for the AC system. The STATCOM energy exchange concept is shown in Figure 3.5.

The current flows from the AC system to the inverter, when the amplitude of V_{out} drops below the bus voltage. The converter therefore absorbs the inductive reactive power of the AC mains. The change of the reactive power becomes zero when V_{out} is equal to the voltage of the AC mains. This time, STATCOM is in floating state. A small reactive DC capacitor is connected in the VSC on the DC side. Therefore, STATCOM can only exchange the reactive power with the transmission system. The equivalent STATCOM circuit is shown in Figure 3.6.

Equation of the magnitude of the alternating current AC is as:

$$I_{ac} = \frac{V_{out} - V_{ac}}{X} \quad (3.5)$$

The alternating current flows from the inverter to the AC system. V_{out} and V_{ac} are the magnitudes of the output voltage of the converter and the voltage of the AC system and X is the reactant of the connection transformer.

Now the reactive power exchanged can be calculated as

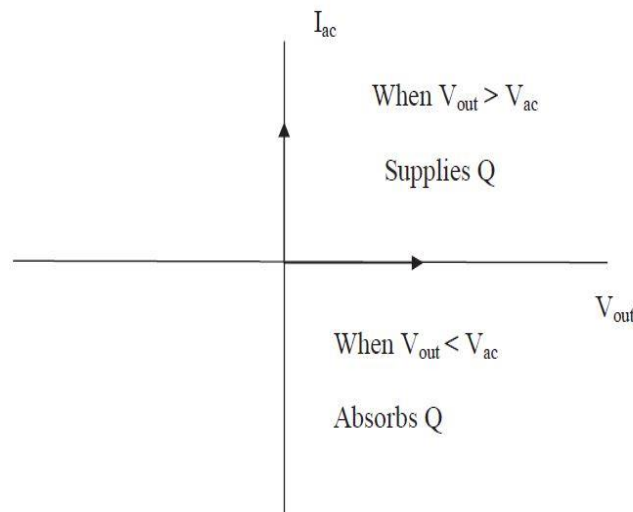

FIGURE 3.5: STATCOM Power exchange [9]

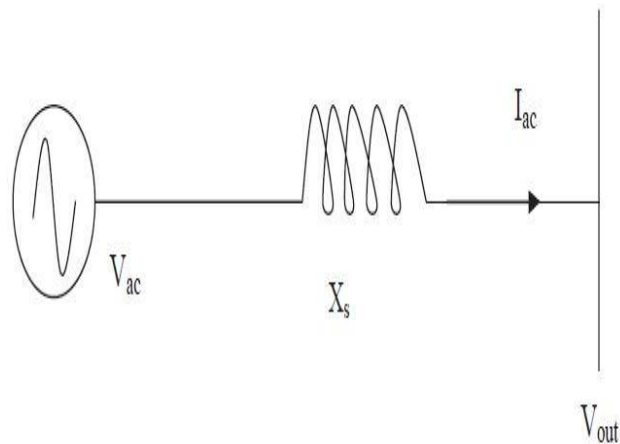

FIGURE 3.6: Equivalent Circuit of STATCOM [9]

$$Q = \frac{V_{out}^2 - V_{out}V_{ac}\cos\alpha}{X} \quad (3.6)$$

Where α denotes the angle between V_{out} and V_{ac} .

Now, the actual power exchange between the AC system and the VSC must be calculated as

$$P = \frac{V_{out} - V_{ac}\sin\alpha}{X} \quad (3.7)$$

The simulink model of STATCOM is given in the tools of Matlab/ simulink library.

The STATCOM simulink model is shown in Figure 3.7.

Internal Structure of STATCOM Simulink Model Figure 3.8.

STATCOM Controller Parameters Figure 3.9

3.2.1 Modeling of STATCOM

The capacitor voltage can be adjusted by controlling the phase angle difference between the main voltage and the voltage VSC. When the firing angles are slightly

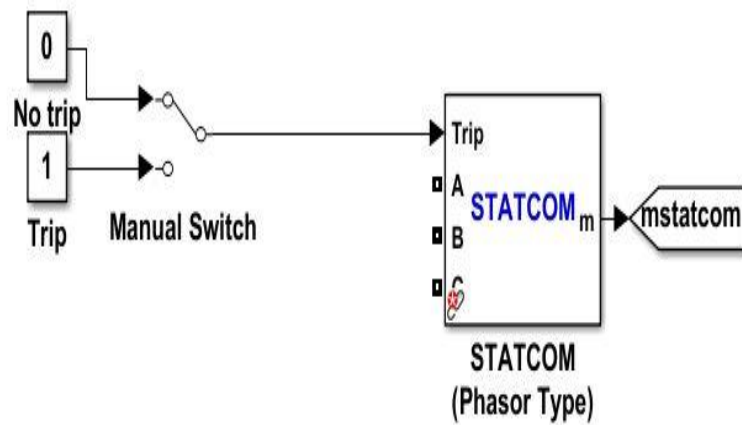

FIGURE 3.7: STATCOM Simulink Model

advanced, the DC voltage decreases and the reactive power flows toward STATCOM. However, if the firing angles are slightly delayed, the DC voltage will increase and STATCOM will supply reactive power to the bus. The voltage regulation can also be achieved by controlling the firing angles of the VSC. The VSC source is a DC capacitor. The DC source may be connected in parallel with the capacitor to support capacitor performance under transient conditions. The

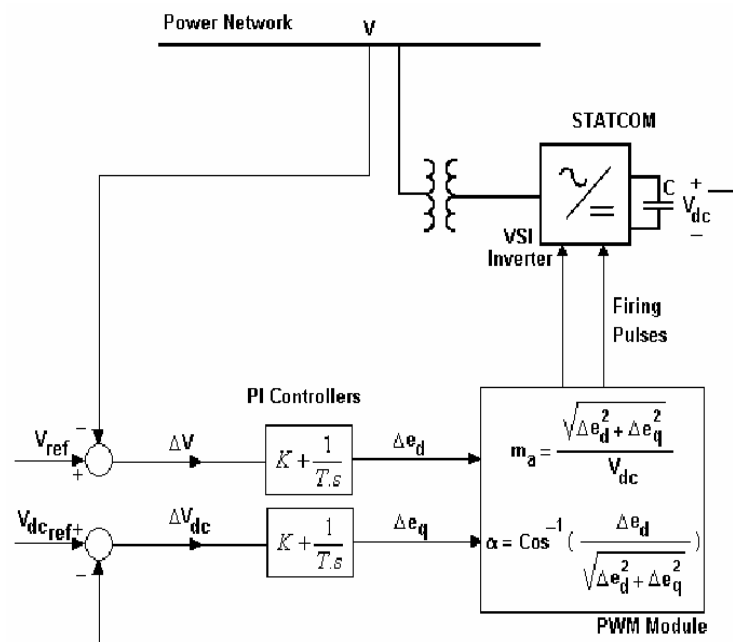

FIGURE 3.8: Internal Structure of STATCOM Simulink Model

Static Synchronous Compensator (Phasor Type) (mask) (parameterized link)
 Implement phasor model of three-phase static synchronous compensator (STATCOM).

Power Controller

Nominal voltage and frequency [Vrms L-L, fn(Hz)]:

Converter rating (VA):

Converter impedance [R(pu), L(pu)]:

Converter initial current [Mag(pu), Pha(deg.)]:

DC link nominal voltage (V):

DC link total equivalent capacitance (F):

FIGURE 3.9: Block Parameter of STATCOM Simulink Model

voltage source converter is connected to a transmission line via bypass transformer, where V_{dc} is the voltage across the DC capacitor, K is the gain of the modulation, and ω is the phase angle of the capacitor fed voltage. The STATCOM consists of a VSC and a capacitor.

Static Synchronous Compensator (Phasor Type) (mask) (parameterized link)
 Implement phasor model of three-phase static synchronous compensator (STATCOM).

Power Controller

Mode:

Reference voltage Vref (pu): External

Maximum rate of change of reference voltage (pu/s):

Droop (pu):

Vac Regulator gains [Kp, Ki]:

Vdc Regulator gains [Kp, Ki]:

Current Regulator gains [Kp, Ki, Kf]:

FIGURE 3.10: Controller of STATCOM Simulink Model

STATCOM VSC is modeled by connecting the 3-arm IGBT bridge. Each IGBT is in parallel with a diode and the output of the inverter must be a sine wave. To obtain the sine wave output at the end of the inverter, a sinusoidal triangular PWM output is provided to the IGBT gates. When the IGBT is ON, the inverter acts as an inverter and the DC capacitor voltage is converted to three-phase AC. The inverter acts as a full-wave rectifier during the IGBT DISCONNECT period and the capacitor is charged to the maximum mains voltage.

The STATCOM control model consists of the following steps, which are listed below:

- o External and internal control circuit current.
- o External control circuit for voltage control.
- o Reactive power compensation and voltage regulation.

3.2.2 Transformation to dq Frame from abc Frame

In the vector form, three (3) electrical phase variables are current, voltage or Flux Figure 3.11.

$$\vec{f}(t) = \frac{2}{3}(fa(t) + fb(t)2\Pi/3 + fc(t)\Pi - j2\Pi/3) \quad (3.8)$$

where $fa(t)$, $fb(t)$, and $fc(t)$, are given as

$$fa(t) = A \cos(\omega t) \quad (3.9)$$

$$fb(t) = A \cos(\omega t - 2\Pi/3) \quad (3.10)$$

$$fc(t) = A \cos(\omega t - 4\Pi/3) \quad (3.11)$$

Where A represents the amplitude of the vector of the electric phase and ω represents the synchronous rotation speed of the spatial vector, that is, 377 rad / s. The spatial vector rotates at the velocity ω in terms of the stationary reference frame. These three (3) phase variables in the stationary reference frame a, b, c can

be converted into two phase variables (2) in a rotating reference frame consisting of the axes q (quadrature) and d (direct). The dq frame rotates at the same speed as in the spatial vector ω . The transformation can be carried out as follows [26]:

$$\begin{bmatrix} fd & fq \end{bmatrix} = \frac{2}{3} \begin{bmatrix} \cos(\omega t) & \cos(\omega t - 2\Pi/3) & \cos(\omega t + 2\Pi/3) \\ -\sin(\omega t) & -\sin(\omega t - \Pi/3) & -\sin(\omega t + 2\Pi/3) \end{bmatrix} \begin{bmatrix} fa(t) \\ fb(t) \\ fc(t) \end{bmatrix} \quad (3.12)$$

Where, fd , and fq are the component of space vector in d-axis and q-axis Figure 3.12[26].

As from transformation, fd and fq are DC quantities. So, the space vector can be expressed as

$$f^{\rightarrow}(t) = (fd + jfq)e^{j\omega t} \quad (3.13)$$

Figure 3.12 [26] indicates the spatial vector (t) in the rotating reference frame (dq) and the stationary reference frame (abc). Angle between the axis a and the axis d is the instantaneous angle Θ . The reference frame dq rotates with a velocity of $\omega = d\Theta/dt$.

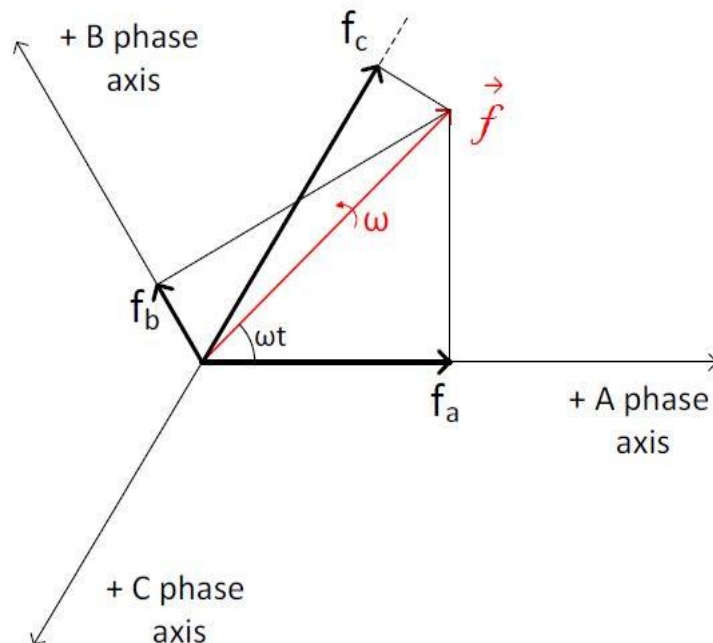

FIGURE 3.11: Three-phase electric variable in vector form [19]

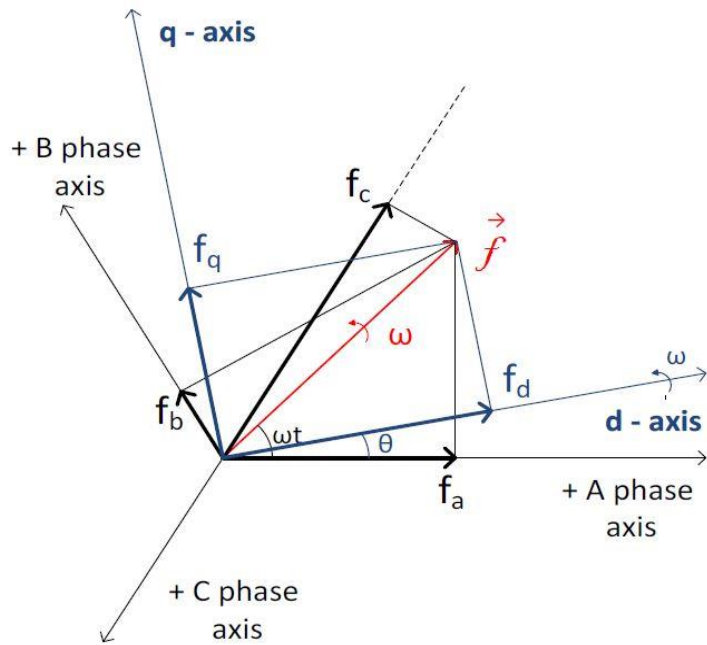

FIGURE 3.12: Three phase electrical variable (abc) and (dq) frame [26]

3.2.3 Modeling of STATCOM Connected to a Grid

STATCOM, a (VSI) with a dc capacitor source, is connected to provide reactive power.

The voltage source of the inverter is made of electric switches, as GTO vs IGBT and transformer.

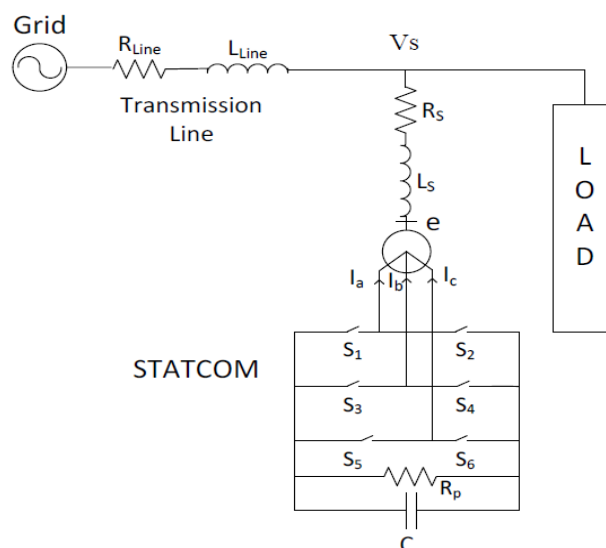

FIGURE 3.13: Schematic diagram of STATCOM connected to Grid [26]

R_p : shows the power losses in capacitor and the switching losses in the inverter

R_s : shows inverter and the transformer conduction loss

L_s : represents the leakage reactance of transformer

I_a, I_b, I_c : the phase current flowing out of STATCOM

The source voltage and the output voltage VSI are represented by V_s and e

V_s : Pcc Voltage

e : VSI output voltage

The output phase voltage of VSI is given by:

$$ea - va = R_s I_a + L_s \frac{dI_a}{dt} \quad (3.14)$$

$$ec - vc = R_s I_c + L_s \frac{dI_c}{dt} \quad (3.15)$$

Now combining all the three phases

$$L_s \frac{dI_a}{dt} = ea - va - R_s I_a \quad (3.16)$$

$$\frac{dI_a}{dt} = \frac{ea - va}{L_s} - \frac{R_s I_a}{L_s} \quad (3.17)$$

$$\frac{dI_b}{dt} = \frac{eb - vb}{L_s} - \frac{R_s I_b}{L_s} \quad (3.18)$$

$$\frac{dI_c}{dt} = \frac{ec - vc}{L_s} - \frac{R_s I_c}{L_s} \quad (3.19)$$

In vector form

$$\begin{bmatrix} I_a \\ I_b \\ I_c \end{bmatrix} = \frac{1}{L_s} \begin{bmatrix} ea - va \\ eb - vb \\ ec - vc \end{bmatrix} - \begin{bmatrix} \frac{R_s}{L_s} & 0 & 0 \\ 0 & -\frac{R_s}{L_s} & 0 \\ 0 & 0 & -\frac{R_s}{L_s} \end{bmatrix} \begin{bmatrix} I_a \\ I_b \\ I_c \end{bmatrix} \quad (3.20)$$

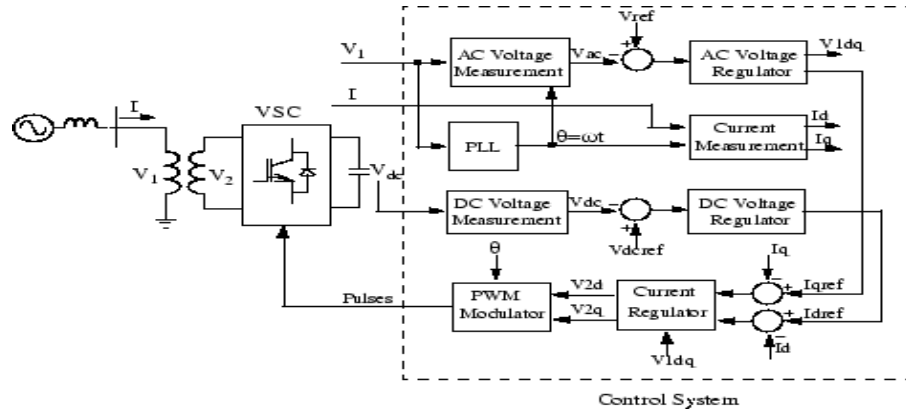

FIGURE 3.14: Basic STATCOM Controller block diagram [26]

Where "P" vector is an operator for d/dt

As

$$L_s \frac{d}{dt} \begin{bmatrix} Idp \\ Iqp \end{bmatrix} = \begin{bmatrix} -R_s & L_{sw} \\ -L_{sw} & -R_s \end{bmatrix} \begin{bmatrix} Idp \\ Iqp \end{bmatrix} + \begin{bmatrix} ed & -vsd \\ eq & -vsq \end{bmatrix} \quad (3.21)$$

d and q denote electrical quantities in the reference frame of the d -axis and the q -axis, respectively.

3.2.4 Basic STATCOM Controller

Figure 3.14 describes the block diagram of the STATCOM base controller. DC link voltage controller maintain the constant voltage of the capacitor. The Reference Signal Generator block provides current reference values, these values must be supplied by STATCOM within the dq. PLL blocks the input voltage V_S as the PCC voltage and generates a signal that will be synchronized with the A phase V_S . At the same time, the STATCOM current is converted to the reference frame dq and the block sequence controller assigned for signal feedback. Controller produces the modulated signals within the dq that are transformed into stationary abc frames and sent to the specified switching section of the inverter.

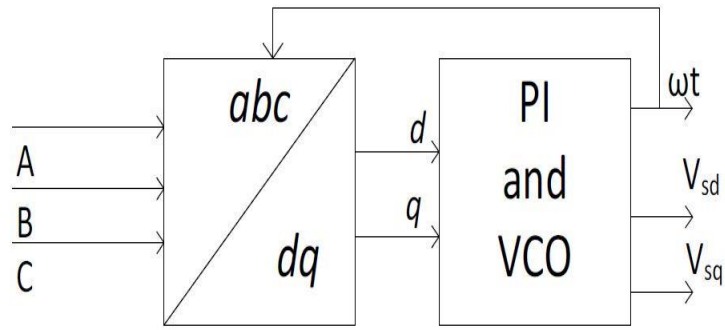

FIGURE 3.15: Phase Locked Loop (PLL) block diagram [26]

3.2.5 Phase Locked Loop (PLL)

The PLL consists of a voltage controlled oscillator (VCO) and PI controller Figure 3.15. The Phase Locked Loop is configured to synchronize the d-axis of the rotation reference frame with phase A. Thus, the voltage vector PCC is $\Theta = 0$. Input signals for PLL are dq components of the PCC voltage. The PI controller is used to obtain $V_{sq} = 0$ and the output angle VCO ωt . The PLL output is the angle ωt used to obtain the transformation of dq (2.3) of the PCC voltage (V_{sd} and V_{sq}). V_{sd} reaches the maximum phase voltage value when it becomes zero.

3.2.6 Real and Reactive Power Control from VSI

In dq reference frame VSI power output equations can be calculated [2]. The reactive power (Q) and real power (P) in dq frame are expressed as:

$$P = \frac{3}{2}(V_{sd}I_{dp} + V_{sq}I_{dp}) \quad (3.22)$$

$$Q = \frac{3}{2}(V_{sq}I_{dp} - V_{sd}I_{qp}) \quad (3.23)$$

Since, PLL calculates $V_{sq} = 0$,

$$P = \frac{3}{2}(V_{sd}I_{dp}) \quad (3.24)$$

$$Q = \frac{3}{2}(-V_{sd}I_{qp}) \quad (3.25)$$

V_{sd} represents the network voltage, which does not change significantly. Therefore, since the VSI power output can be controlled with I_{dp} and I_{dq} . Therefore, to obtain the reference power I_{dpref} and I_{dqref} , from VSI, current output as follow:

$$I_{dpref} = \frac{2}{3V_{sd}}(P_{ref}) \quad (3.26)$$

$$I_{dqref} = -\frac{2}{3V_{sd}}(Q_{ref}) \quad (3.27)$$

The operation of Reference Signal Generator block is explained by the equation presented in Figure 3.13.

3.3 Modeling of Wind Energy System

For wind power conversion, it is necessary to design and implement a model controller for wind turbines. The mathematical model and analysis of the wind turbine are given in this chapter. The discussion starts with the wind source and its characteristics properties.

3.3.1 Source of Wind and Characteristics Properties

Wind is produced by the differences in atmospheric pressure resulting from the uneven heating of the surface by the sun [27]. The sun warms the atmosphere, making one areas warmer than other. These warm areas increase the air, others blow air to replace them and blow out the wind. Land irregularities and earth rotation, solar thermal capacity, cooling effect of the oceans and temperature gradients of polar ice sheets between sea and land contribute to the wind flow [26].

The sun warms the earth stronger during the day than the sea. The hot air rises and creates a low ground pressure that attracts fresh sea air [27].

Since the water cools down more slowly at night than the earth, the wind welcomes the opposite direction. Larger land breezes usually have lower wind speeds,

as the temperature differences between ground and sea are lower during the night, Similar blizzards occur in the mountains, while hot air rises along hot slopes [31]. During the night, the most beautiful air goes down the hill. The global wind flow in a given area is due to the change in temperature between the poles and the equator and the local wind [4].

3.4 Modeling of Wind Turbine

As wind is the flow of air that posses energy(KE). The KE is then transformed into mechanical energy by means of turbine blades.

3.4.1 Power in Wind

Let the m is the mass of air that flows through area of A with a velocity of V. So kinetic wind energy is given by [28].

$$K.E = \frac{1}{2}mvv^2 \quad (3.28)$$

Here,

m = air mass (kg)

v = speed/s)

$$vw = \text{windspeed} \frac{m}{s} \quad (3.29)$$

As Power is energy per unit time, so equation becomes [28]:

$$P_{wind} = \frac{1 \times \text{mass}}{2 \times \text{time}} = \frac{1}{2} \times \frac{m}{t} \times VW^2 \quad (3.30)$$

Since the equation (2-2) can be written as

$$P_{wind} = \frac{1}{2}Avv^3 \quad (3.31)$$

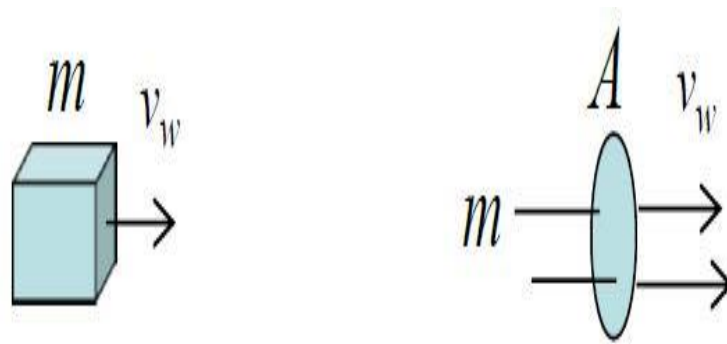

FIGURE 3.16: Mass 'm' of Air flows through an Area A [28]

Where, P_{wind} = wind power (W)

ρ = air density (kg/m³)

A = cross-sectional area (m²)

3.5 Modeling of Wind Turbine Connected with Weak Grid

3.5.1 Single Wind Turbine Simulation using MATLAB/SIMULINK

The MATLAB-SIMULINK environment examines the impact of STATCOM on the performance of the wind turbine connected to a weak network. The wind turbine is initially connected to the weak grid without STATCOM Figure 3.17.

As due to the absence of reactive power compensator STATCOM and weak grid the wind turbine shutdown due to the low reactive power provided by weak grid to the wind turbine.

Now the second behavior is studied in the presence of STATCOM along with the wind turbine is connected to a weak grid. So due to the presence of reactive power compensator STATCOM, the wind turbine do its operation well Figure 3.18.

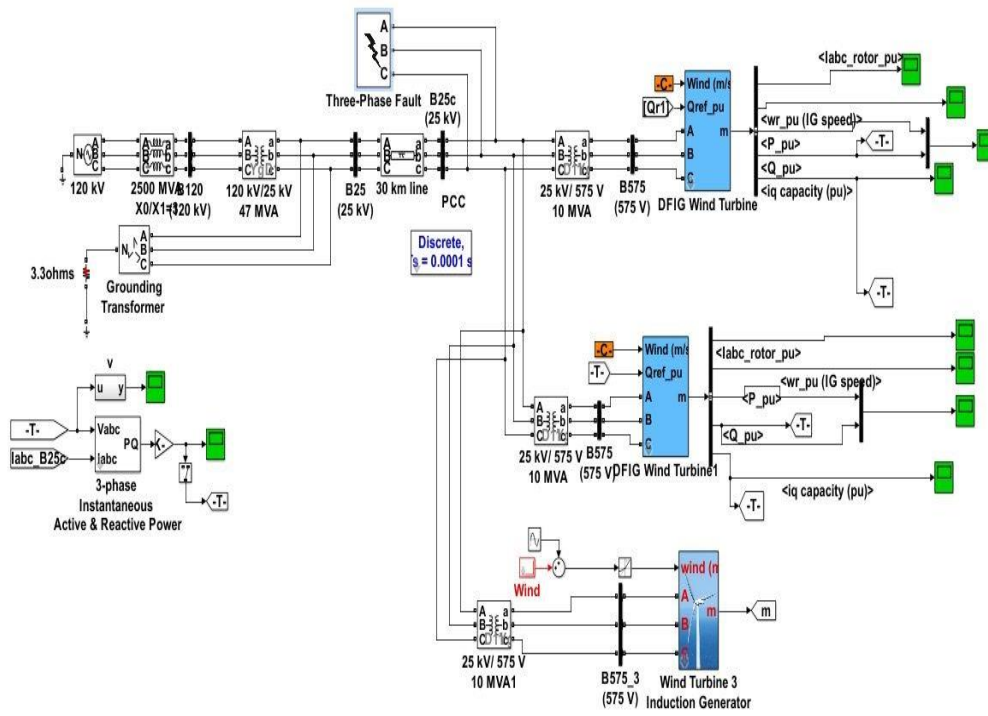

FIGURE 3.17: Wind Turbine connected with Weak Grid without STATCOM

In third scenario now the weak grid is much better than the previous weak grid integrated with one turbine and fault is generated at turbine side, and checked

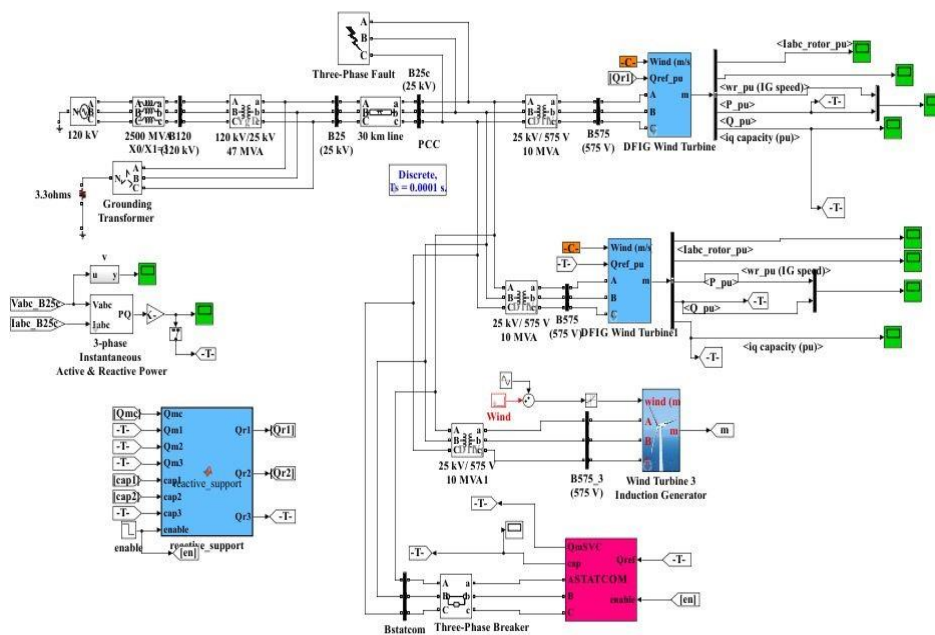

FIGURE 3.18: Wind Turbine connected to Weak Grid with STATCOM

system behavior Figure 3.19. In this case the wind turbine is in operational mode but during turbine fault the wind turbine shutdown due to voltage dip caused by low reactive power. But after connecting STATCOM, voltage dip and low reactive power issue is resolved by providing reactive power to wind turbine by reactive power compensator device such as STATCOM.

In all of these cases, a PI-based controller value for STATCOM is set and its performance is examined with MATLAB SIMULINK. The modeling of STATCOM with the energy system is done via Simpower tool cabinets in MATLAB / SIMULINK. The modeling is done by connecting a three-phase power source and a wind turbine. The AC voltage at the source is kept at 132 kV and the frequency is 50 Hz.

3.5.2 Multiple Wind Farm Connected with Weak Grid

The system consists of 18 mega watt DFIG wind farm and 6 mega watt wind farm of FSIG, consisting of 6 wind turbines for DFIG and 4 FSIG having capacity of 1.5 megawatt or 9 mega watt wind turbine and 6 mega watt of 1.5 MW. The wind turbine transfers power to a network of 132k over a 25 kilo-meter transmission

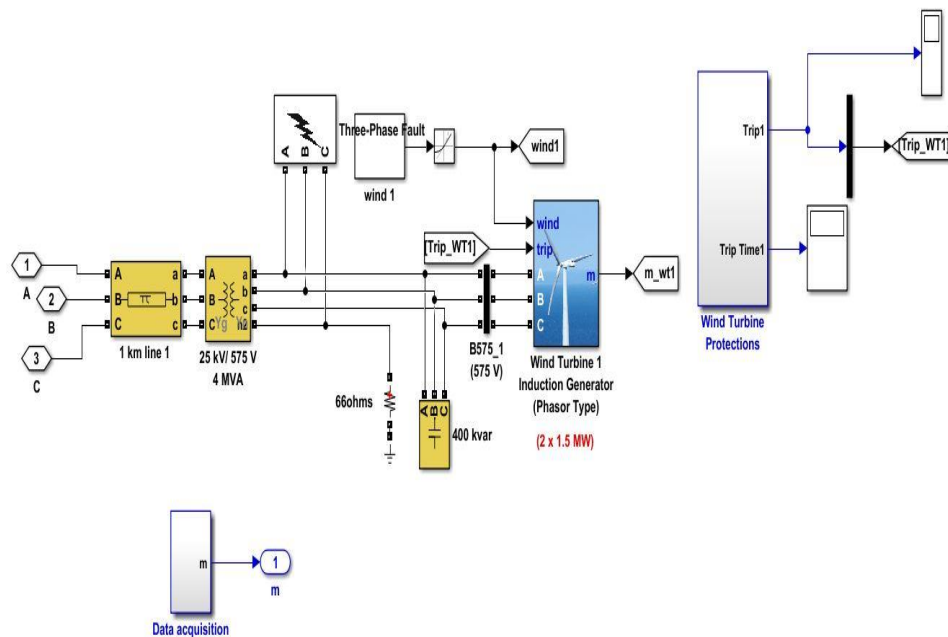

FIGURE 3.19: Turbine With Fault

TABLE 3.1: System Model Values

Parameters	Values
V base	132kv
P base	9MW
F base	50Hz

TABLE 3.2: 9MW induction wind turbine model parameters

Parameters	Values
Resistance of Stator (Rs)	0.004843 pu
Resistance of Rotor (Rr)	0.004377 pu
Reactive power of STATCOM	3 Mvar

line.

The system specifications are listed in Tables 1 and table 2:

Chapter 4

Simulation Results

This chapter presents the obtained results of complete model. The wind farm connected to a 25-kV distribution system exports power to a 132-kV grid through a 25-km 25-kV feeder. Simulink Matlab software for model simulation. This model discusses the effect and response of DFIG wind turbine and fixed speed wind turbine during three phase-fault on wind turbine on the system studied to depicts the following:

Three wind turbine rotor speed, active, reactive power, and voltage on 25kV bus with and without STATCOM will be discussed. The simulation results consist of the following steps.

In first simulation, wind turbine is connected to weak grid in the presence of fault. In the second simulation, STATCOM is introduced along with fault. So we will see a better results and performance due to the presence of STATCOM.

In this chapter the effect of speed on wind turbines is studied. Which depicts the following: wind turbine rotor speed, active,reactive power, and voltage on 25kV bus with and without STATCOM. Figure 4.1 shows complete model of the System.

The induction generator speed must be above that of the synchronous speed for the purpose to generate power. This Speed varies approximately between 1 pu

and 1.005 pu at no load and at full load respectively. Each wind turbine has a protection system monitoring voltage, current and machine speed.

The complete system model consists of source, three phase measurement block, the transformer, statcom and wind turbines. Besides this data acquisition description circuit of wind farm and data acquisition circuit of bus line is present. The wind farm data acquisition description circuit describes about fault in the system Figure 4.2. When any fault in the system occurs, it generates an alarming to indicate the fault. For the instant if there is voltage dips or ac over current then an alarming indication is generated to show the system fault behavior. The bus line data acquisition description circuit takes the signal from bus line Figure 4.3.

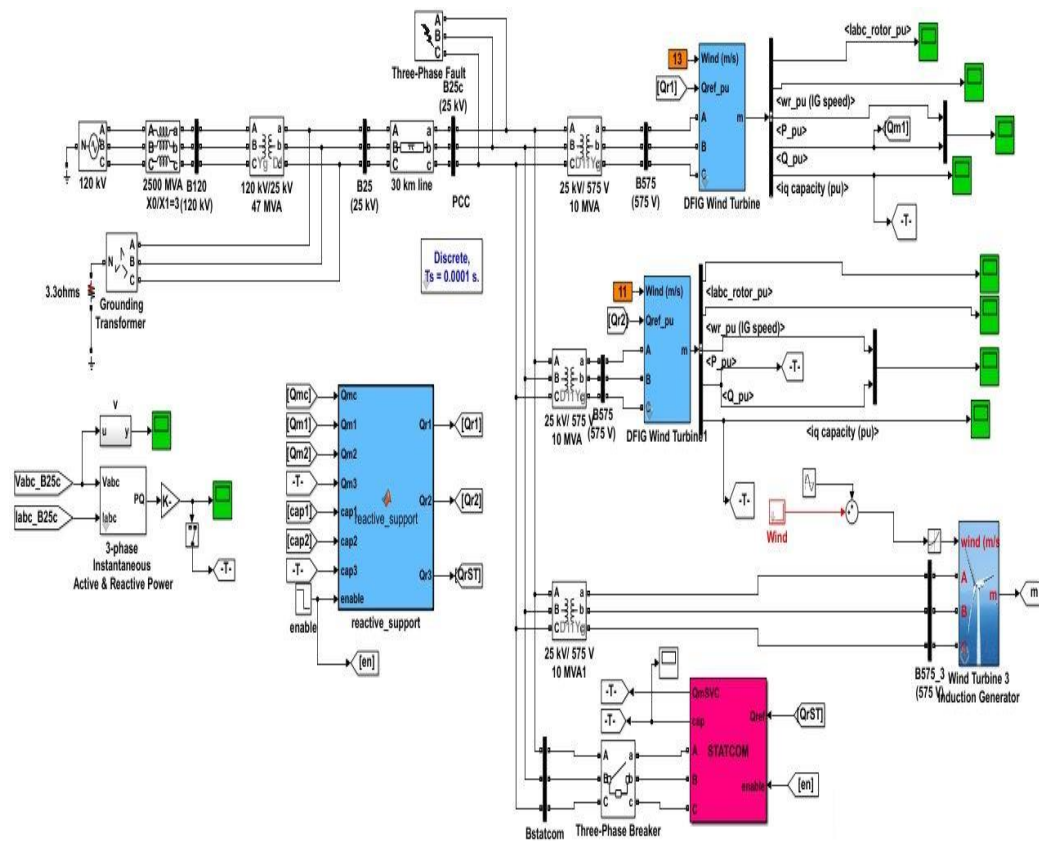

FIGURE 4.1: Complete System Model

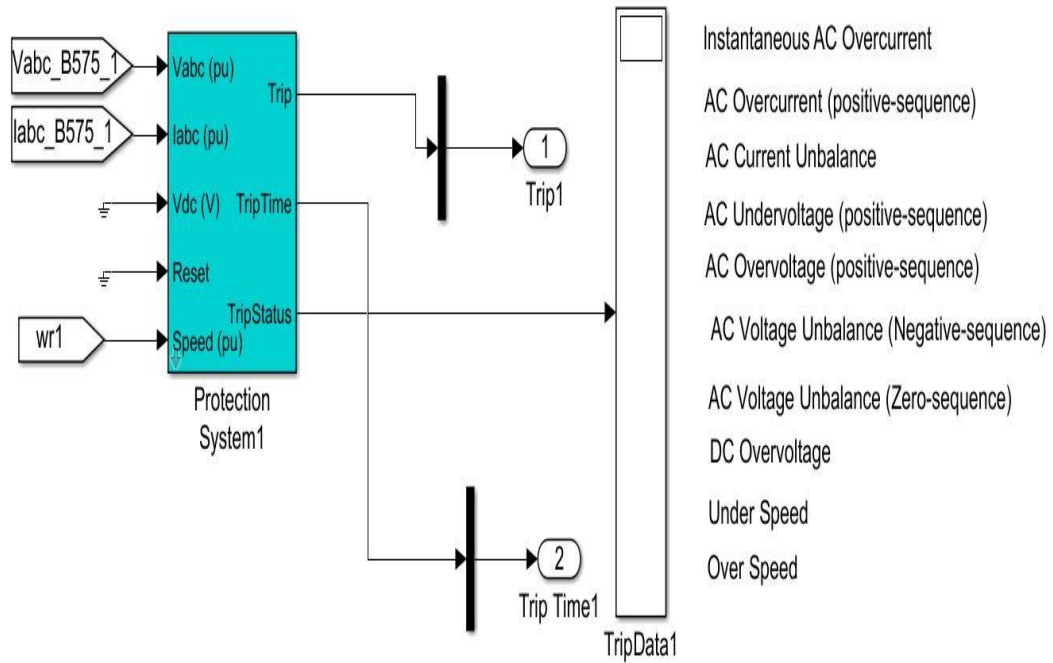

FIGURE 4.2: Data Acquisition description circuit wind farm

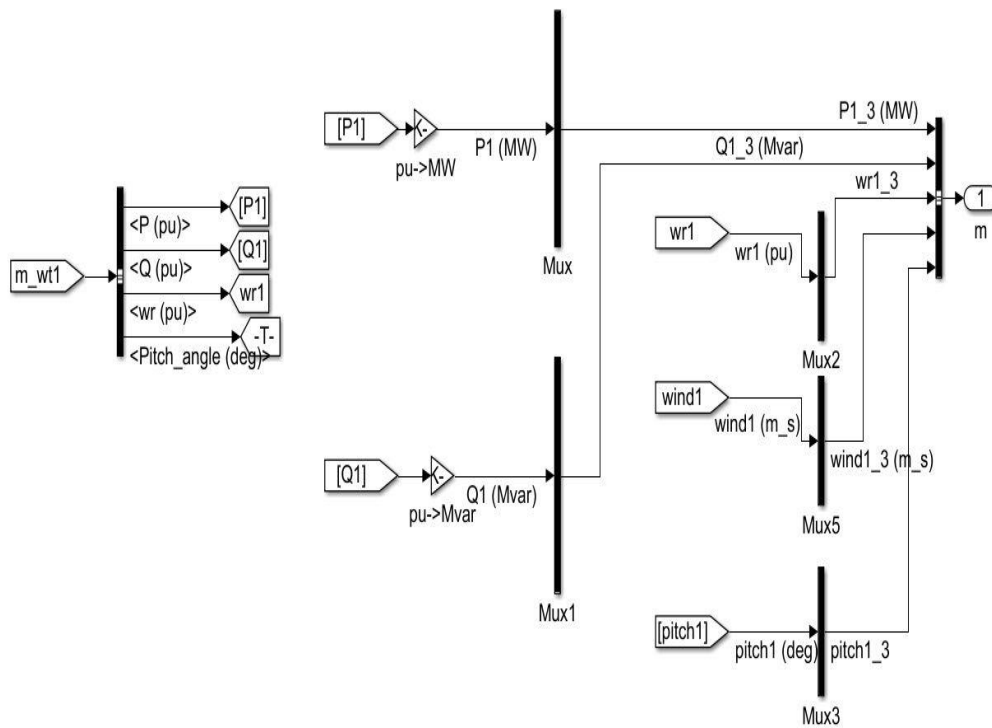

FIGURE 4.3: 25kV Bus Data Acquisition Circuit

4.1 Simulation of Wind Turbine Connected to Weak Grid

Weak network means that the power is lower and the connected load can not be sufficiently supplied with power and the SCR value is below 20 and the X/R ratio below 5 is considered a weak network Figure 4.4.

4.2 Simulation of Weak Grid with Fault

The simulation is performed in the presence of fault at the time of 3 second which is cleared after 0.1 second. It is assumed that a line to the ground fault in the connection of the wind turbine at 3 second and last for 0.1 second ($t = 3.1$ second). The first wind farm is operating without affecting its active and reactive power and

Three-Phase Source (mask) (link)
Three-phase voltage source in series with RL branch.

Parameters Load Flow

Configuration: Yg

Source

Specify internal voltages for each phase

Phase-to-phase voltage (Vrms): 132e3

Phase angle of phase A (degrees): 0

Frequency (Hz): 50

Impedance

Internal Specify short-circuit level parameters

3-phase short-circuit level at base voltage(VA): 9e6

Base voltage (Vrms ph-ph): 132e3

X/R ratio: 4

FIGURE 4.4: Parameters of Weak Grid

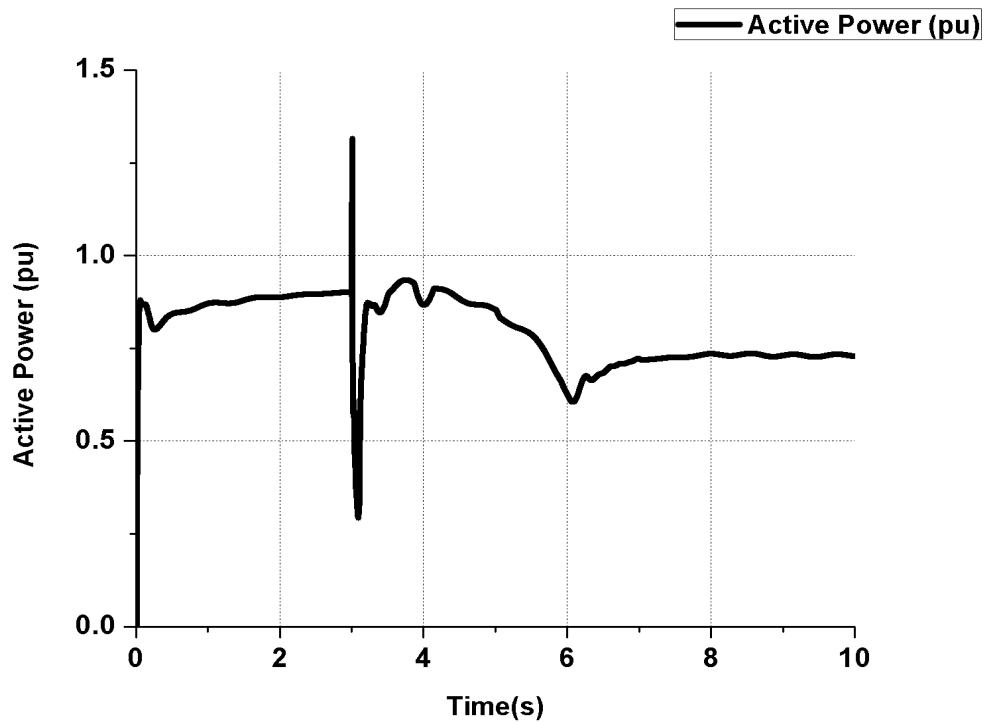

FIGURE 4.5: Active Power Turbine1

contributing its power to the distribution system.

Due to the presence of three phase fault, the power capability of second wind turbine is effected and its rating power is decreased. The follow graphs shows the active power and reactive power of second wind turbine.

During fault at wind turbine side, which is cleared after 100 ms, i.e., 3 second to 3.1 second. It can therefore be seen that the third wind turbine triggers the voltage at the bus 25 kV due to the lack of reactive power support and drops to 0.57 pu at $t = 3.1$ second. When a phase-to-ground fault occurs, the third wind turbine accelerates at $t = 3$ second. Due to lack of reactive power and electrical torque of an induction generator. The third turbine is triggered by a protection system, so the first and second wind turbine is responsible for providing active and ractive power to the 25 kV bus.

Since the third wind turbine is shut down by a protection system. Thus, only first and second turbine is responsible for providing the reactive power. The following

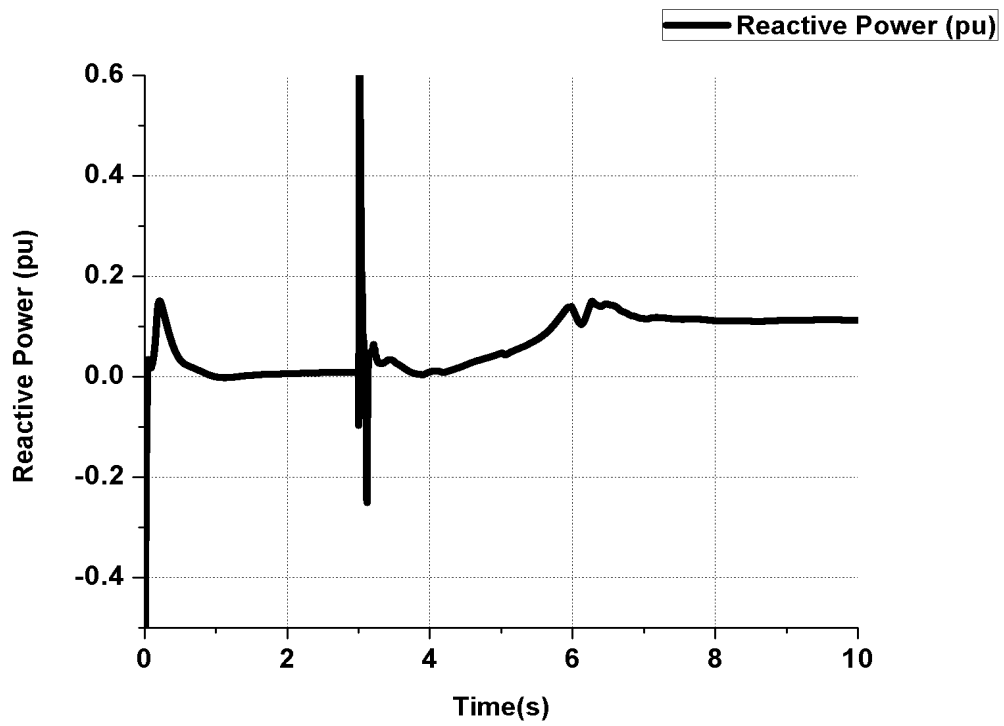

FIGURE 4.6: Reactive Power Turbine1

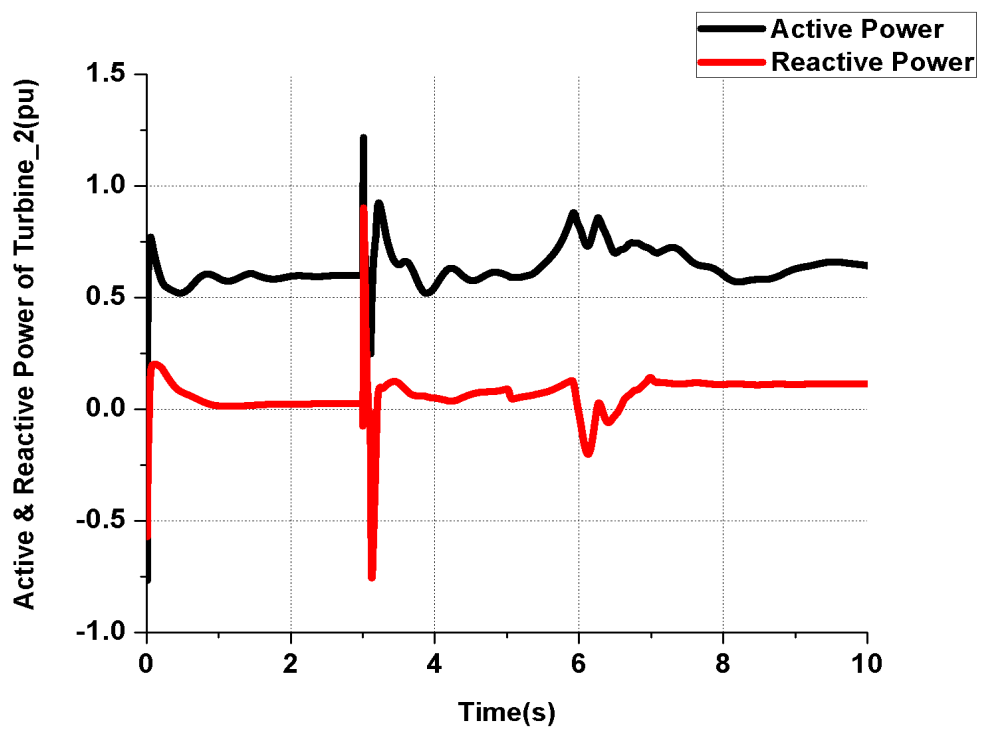

FIGURE 4.7: Active and Reactive Power Turbine2

graphic shows the reactive power of three turbines Figure 4.6 and Figure 4.7.

Now the behavior of the rotor speed in the fault state is examined. The fault is generated after 3 seconds, which is lost for 3.1 second. During this time, the rotor speed of turbine third also accelerated and hence lost its stability and is shut down by a protection system. The second turbine degraded its power due to voltage drops at the time of 3.1 seconds. Thus, only the first turbine is responsible for maintaining the system stresses. The following simulation graph shows the system bus voltages Figure 4.11.

It can be seen that the impact of change in wind speed, turbine has a low voltage condition. which results in an overloading of the induction generator of wind turbine3 causing to tripped at time 3.1 second by the AC over current protection system. Moreover it is observed that voltage has dropped due to low reactive power to induction generator and is shut down by the system.

The reason is that the wind turbine cannot absorb enough reactive power due to decrease in electrical torque. SO the FSIG lost its stability and the rotor speed of FSIG is increased. Without STATCOM, it is clear from the simulation results

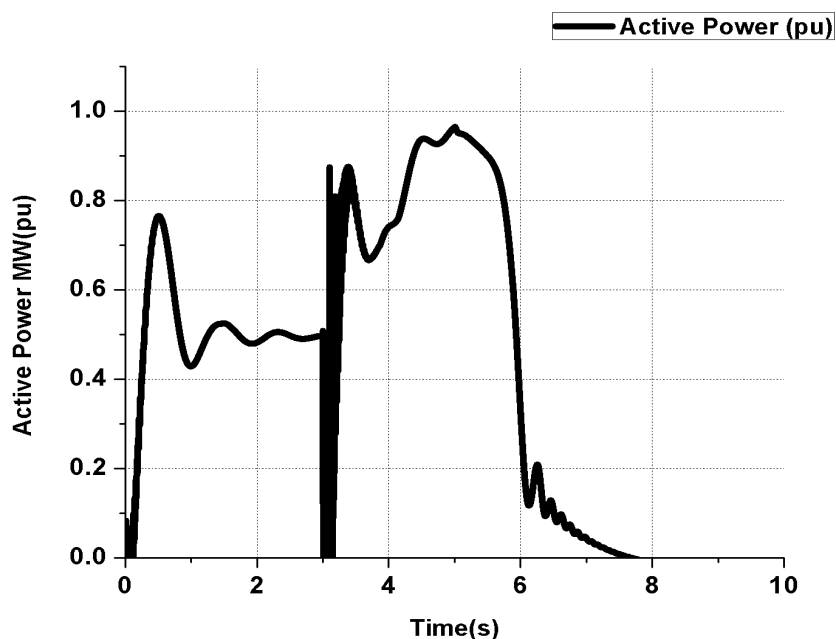

FIGURE 4.8: Active Power Turbine3

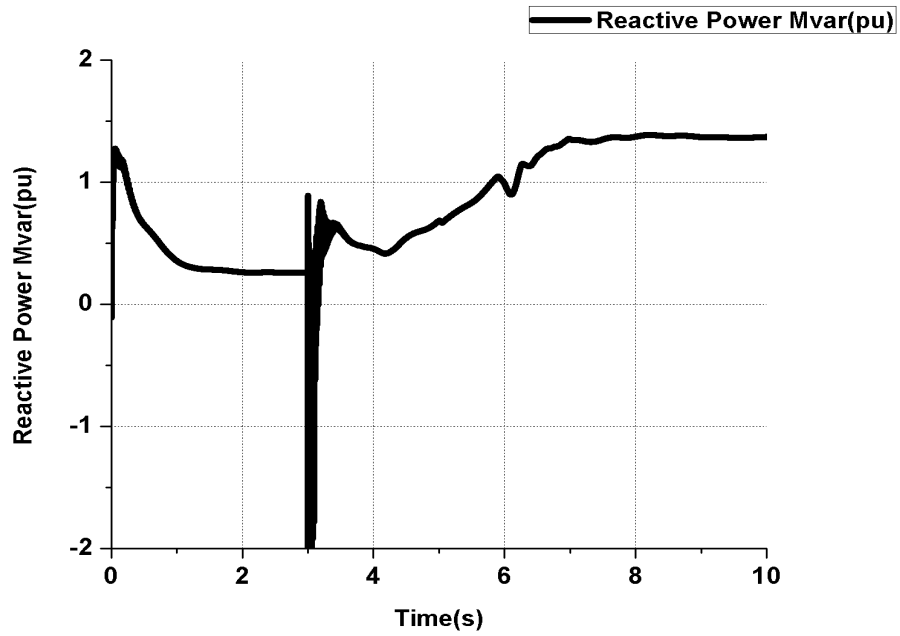

FIGURE 4.9: Reactive Power Wind Turbine3

that the third wind turbine is tripped because of the lack of reactive power support as occurrence of line to line to ground fault on time $t=3$ second last for 0.1

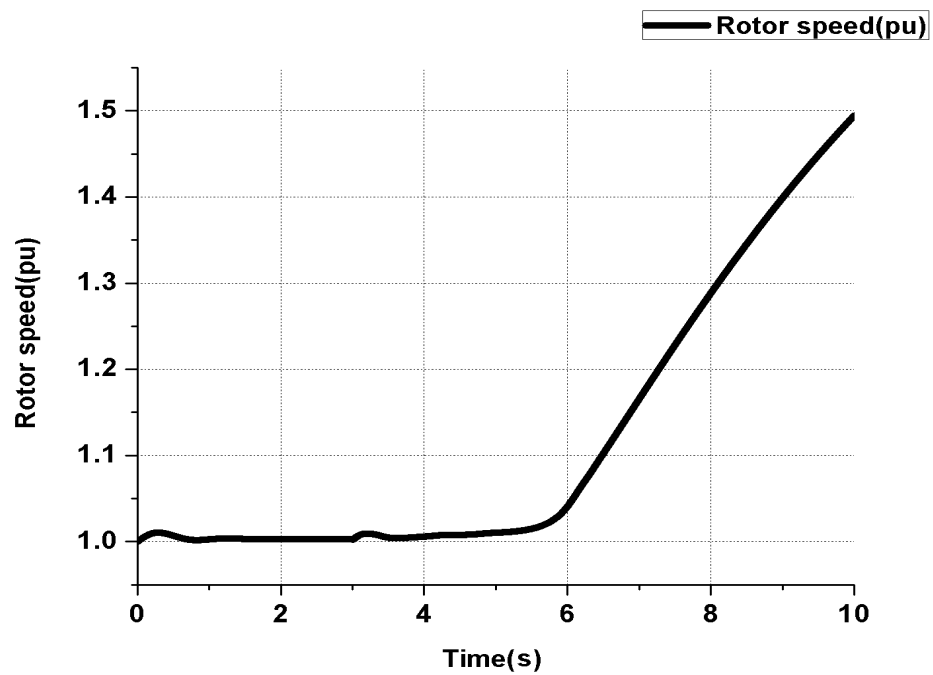

FIGURE 4.10: Rotor Speed Wind Turbine3

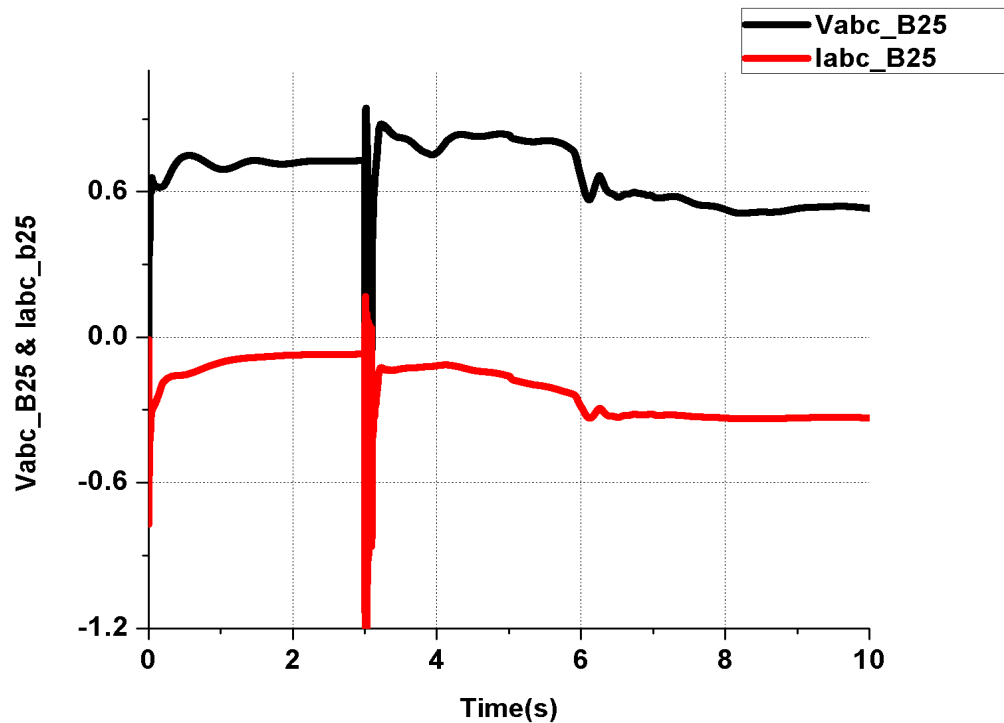

FIGURE 4.11: Voltages Bus Line25(pu)

second $t=3.1$ seconds, the voltage at bus 25kV, drops to 0.57pu at $t = 3.1$ sec. Rotor speed of turbine 3 begins to accelerate hence tripped by the protection system Figure 4.10.

4.3 Behavior of Grid with Fault and STATCOM

Initially the wind speed is set 8 m/s, and after 2 seconds delay, the wind turbine speed approaches to 11 m/s. During the time when the wind speed from 8 m/s to 11 m/s, some of power fluctuations appears in the system during approaches to constant speed. So in the present scenario, the wind turbine is connected via a transmission line to a weak grid along with the presence of STATCOM. The behavior of the system is investigated with fault and also with the presence of reactive power compensator STATCOM. The total simulation time of 10 seconds is considered.

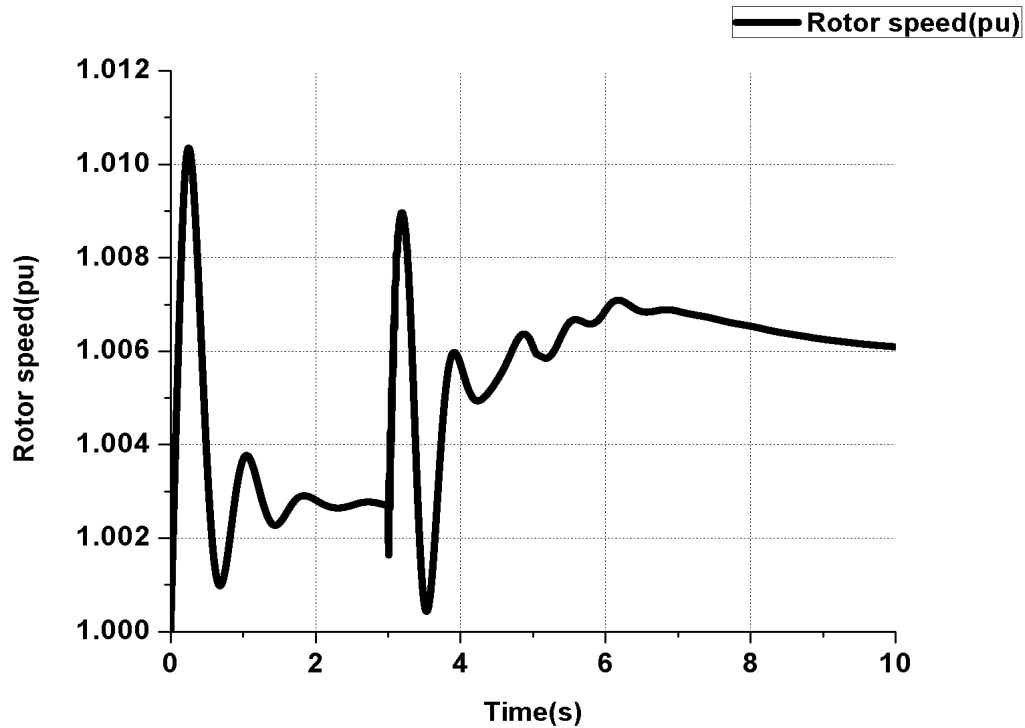

FIGURE 4.12: Rotor Speed of Wind Turbine3

Here, the simulation results of the same network configuration along with additional of 3MVar STATCOM is introduced. It is obvious that the third wind turbine which was removed by protection system on time, $t=3$ second due to fault at time, $t=3.1$ second is recovered by the reactive power compensator STATCOM. Now to solve the reactive power issue and improve the performance of each wind farm, STATCOM is introduced to provide the required reactive power.

By keeping STATCOM value constant, the behavior of the rotor speed of turbine 3, which was accelerated due to less availability of reactive power and the instability in wind turbine 3 due to extreme absorption by FSIG wind turbine. Also the sudden drop in AC voltage which was caused by the FSIG's electrical torque reduction i.e. unbalanced of electrical torque.

This unbalancing was caused by the difference between fixed mechanical torque and electrical torque and caused the rotor to accelerate is now recovered by the compensation of additional Mvar value of STATCOM.

The rotor speed which was accelerated due to occurrence of line to line to ground

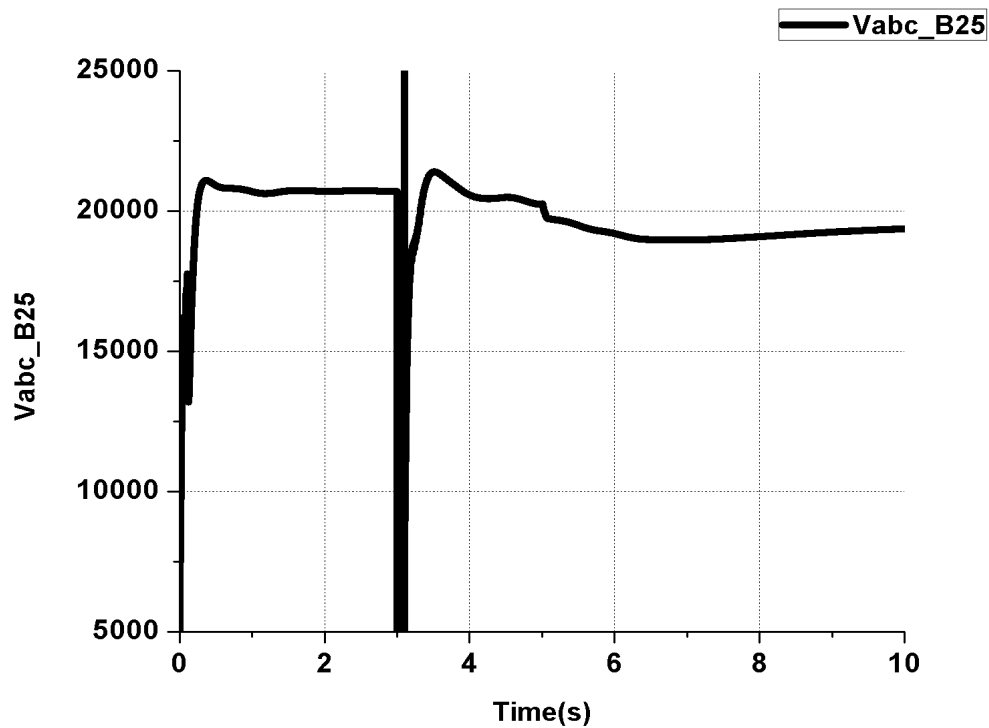

FIGURE 4.13: Voltage Bus Line

fault on time $t=3$ second last for 0.1 second time, $t=3.1$ second and also the second DFIG wind turbine which power is degraded due to fault occurrence are now resolved.

Due to compensation of reactive power, the AC voltage return to pre-fault value. This is because the rotor slip cannot change instantaneously because of mechanical restrictions. So a large amount of reactive power is absorbed by FSIG and the electrical torque becomes greater than mechanical torque.

It causes to decelerate the rotor speed and also decreases the slip. The reduction of rotor slip and deceleration of FSIG wind turbine lead to reduction of reactive energy absorption by FSIG. So as a result the AC voltage causes to increase. Now finally, reactive power and electrical torque come back to steady state and the system becomes stable.

After compensation of STATCOM and also when the three phase fault occurred at turbine side, which is cleared after 100 ms i.e. time =3 second to 3.1 second. it can therefore be seen that the performance of the second wind turbine which

was degraded due to fault is now improved.

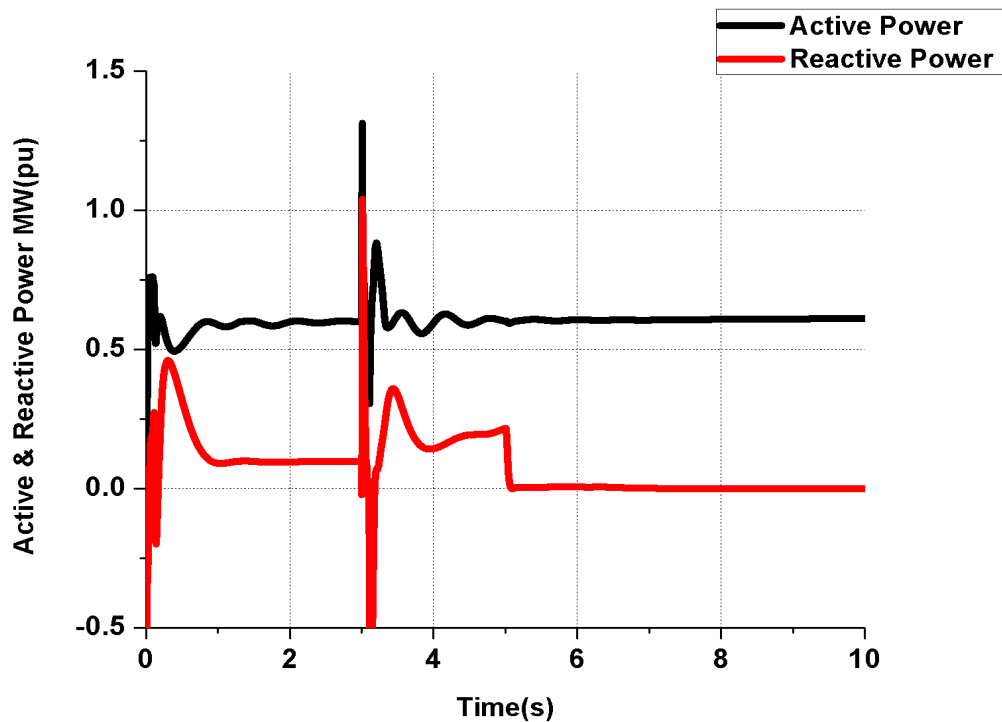
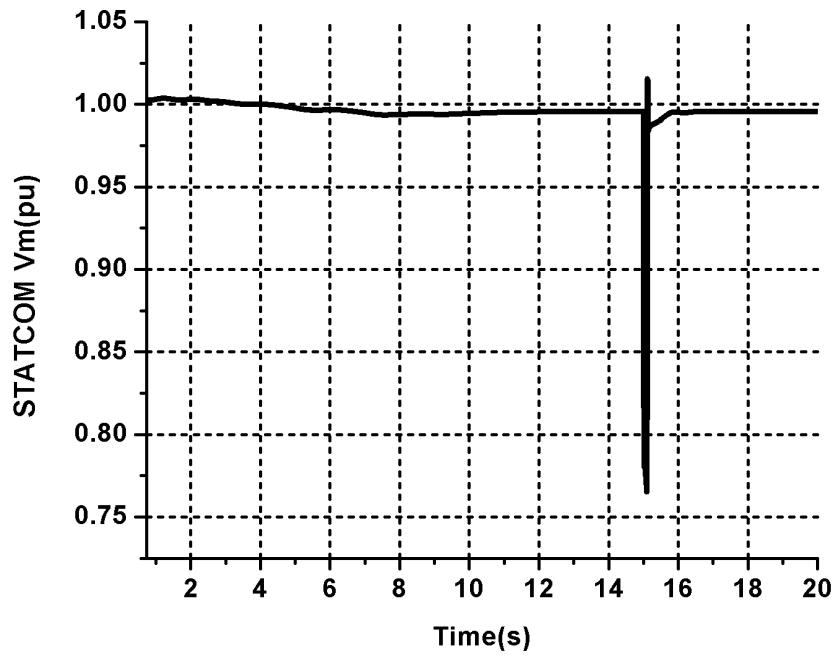
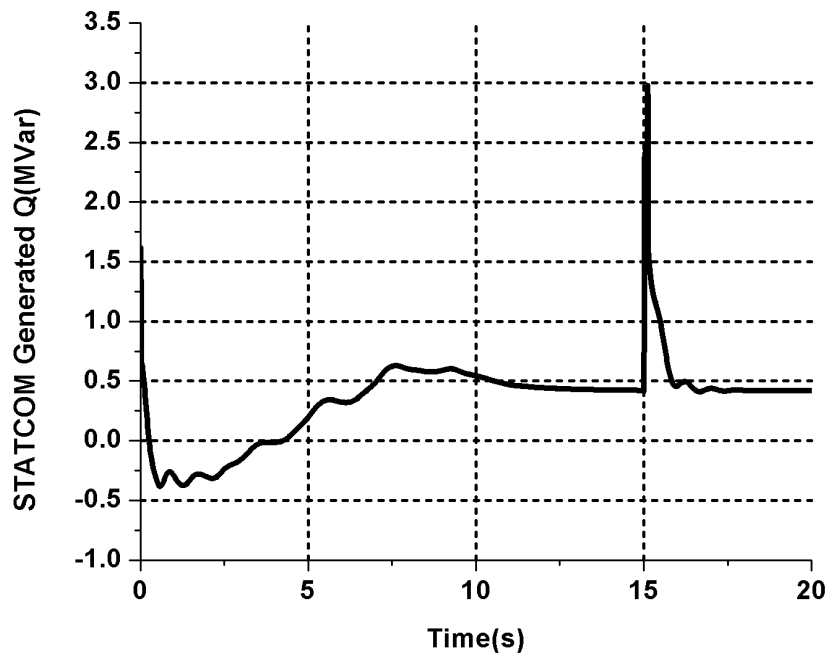

FIGURE 4.14: Active and Reactive Power of Wind Turbine3

Similarly the reactive power of third wind farm also comes to its stable form. The reactive power of three wind turbines after connecting static synchronous compensator STATCOM. The STATCOM is now providing reactive power to the turbine which was shut down due to voltage dips and fault at 3 second to 3.1 second. The rotor speed accelerated due to occurrence of line to line to ground fault on time $t=3$ second last for 0.1 second time, $t=3.1$ seconds. Moreover the power degradation of second DFIG wind farm are now resolved.

The contribution of reactive power compensator STATCOM to the system and its injected power to the system:

The STATCOM controller powered the system, exposing the system to various errors, such as noise and performance conditions. Result demonstrate the performance of the proposed STATCOM controller in terms of stability enhancement, damping of voltage fluctuations, voltage regulation, increase in power transfer, and, above

FIGURE 4.15: STATCOM V_m (pu)FIGURE 4.16: STATCOM Generated Q (MVar)

all, as a provider of controllable reactive power to accelerate the recovery of voltage after a fault occurs.

Chapter 5

Conclusion and Future Work

In this chapter conclusion and future work are discussed, area of this research is so vast and there are many opportunities for new research. Future recommendations are discussed also.

5.1 Conclusion

The urgent need to combine natural resources with electricity has led to a high demand for energy from renewable energy sources such as wind, biogas and solar energy. The production that comes from such natural resources is of a changing nature. For this purpose, an alternative method is needed for the efficient control of energy for these energy sources. In the past, a high penetration of wind energy has been observed and the interconnection requirements to the grid have been efficiently developed. Therefore, a wind turbine has the ability to cross a fault without cutting the wind turbines of the network. Efficient power control is required when a wind farm and a weak electrical network are connected. Therefore, there is good performance control under normal operating conditions and good support during and after faults. In the power system, a voltage instability problem occurs that does not satisfy the required demand for reactive power when

a fault occurs. The effective measure of maintaining the quality of the energy and the stability of the voltage is the dynamic compensation of the reactive energy. When more than two turbines are connected to the system, as a result, the network weakens. Therefore, these generators require more efficient equipment for stability. As they do not have the capacity of self-recovery as synchronous generators. This requires investigation of the dynamic and normal performance of wind turbines during and after failures. This thesis work examines the idea of connecting STATCOM to wind turbines in order to provide effective reactive power. Here, the wind farm models are DFIG and FSIG, which need a compensation of the reactive power during disturbances on the side of the network. Therefore, when connected to a weak network, STATCOM can provide the required reactive power. In addition, a higher degree of STATCOM can be used to efficiently manage stress and increase wind farm reliability, but the economic aspects restrict its classification.

The simulation results show that the additional voltage support provided by an external device such as STATCOM can significantly improve wind turbine recovery by quickly restoring voltage characteristics. The extent to which STATCOM can support this depends on the rating. At higher rating, more support is offered. Wind turbine connections with weak networks also affect the safety of wind turbines. Challenges facing wind turbines when connected to weak grid increase the number and frequency of failures, grid irregularities, voltage and frequency variations that can cause wind turbines. Dynamic power of wind turbines has been improved by STATCOM in the power grid. The wind turbine response to sudden load variations is improved by using STATCOM.

5.2 Future Work

The simulation studies in this work show that the dynamic performance of wind farms has been improved with STATCOM. Future work may include the analysis of harmonics in the system and evaluate methods for reducing harmonics in

the system. A multilevel STATCOM can reduce the harmonics of lower order. In this work, high-impedance three-phase short-circuit faults were investigated, which can be extended to analyze the system's response to other types of faults. The wind turbines modeled here are the hybrid wind farm i.e. DFIG and FSIG wind turbines. The study is based solely on DFIG and FSIG performance but can be extended to other wind turbine types and larger systems that evaluate the support provided by STATCOM.

Bibliography

- [1] R. Renewables, “Global status report,” *Renewable Energy Policy Network for the 21st Century*, 2012.
- [2] W.-M. Chen, H. Kim, and H. Yamaguchi, “Renewable energy in eastern asia: Renewable energy policy review and comparative swot analysis for promoting renewable energy in japan, south korea, and taiwan,” *Energy Policy*, vol. 74, pp. 319–329, 2014.
- [3] Y. Wang and L. Xu, “Coordinated control of dfig and fsig-based wind farms under unbalanced grid conditions,” *IEEE Transactions on Power Delivery*, vol. 25, no. 1, pp. 367–377, 2010.
- [4] S. Muller, M. Deicke, and R. W. De Doncker, “Doubly fed induction generator systems for wind turbines,” *IEEE Industry applications magazine*, vol. 8, no. 3, pp. 26–33, 2002.
- [5] J. Hu, H. Nian, H. Xu, and Y. He, “Dynamic modeling and improved control of dfig under distorted grid voltage conditions,” *IEEE transactions on energy conversion*, vol. 26, no. 1, pp. 163–175, 2011.
- [6] M. Mohseni, S. M. Islam, and M. A. Masoum, “Enhanced hysteresis-based current regulators in vector control of dfig wind turbines,” *IEEE Transactions on Power Electronics*, vol. 26, no. 1, pp. 223–234, 2011.
- [7] R. Cardenas, R. Peña, S. Alepuz, and G. Asher, “Overview of control systems for the operation of dfigs in wind energy applications,” *IEEE Transactions on Industrial Electronics*, vol. 60, no. 7, pp. 2776–2798, 2013.

-
- [8] H. Li and Z. Chen, "Overview of different wind generator systems and their comparisons," *IET Renewable Power Generation*, vol. 2, no. 2, pp. 123–138, 2008.
- [9] X. Wu, A. Arulampalam, C. Zhan, and N. Jenkins, "Application of a static reactive power compensator (statcom) and a dynamic braking resistor (dbr) for the stability enhancement of a large wind farm," *Wind Engineering*, vol. 27, no. 2, pp. 93–106, 2003.
- [10] A. A. Kadir, A. Mohamed, and H. Shareef, "Harmonic impact of different distributed generation units on low voltage distribution system," in *Electric Machines & Drives Conference (IEMDC), 2011 IEEE International*, pp. 1201–1206, IEEE, 2011.
- [11] H. Chen, N. David, and D. C. Aliprantis, "Analysis of permanent-magnet synchronous generator with vienna rectifier for wind energy conversion system," *IEEE Transactions on Sustainable Energy*, vol. 4, no. 1, pp. 154–163, 2013.
- [12] M. E. Haque, M. Negnevitsky, and K. M. Muttaqi, "A novel control strategy for a variable speed wind turbine with a permanent magnet synchronous generator," in *Industry Applications Society Annual Meeting, 2008. IAS'08. IEEE*, pp. 1–8, IEEE, 2008.
- [13] S. M. R. Kazmi, H. Goto, H.-J. Guo, and O. Ichinokura, "A novel algorithm for fast and efficient speed-sensorless maximum power point tracking in wind energy conversion systems," *IEEE Transactions on Industrial Electronics*, vol. 58, no. 1, pp. 29–36, 2011.
- [14] E. T. Gross and M. H. Hesse, "Electromagnetic unbalance of untransposed transmission lines," *Transactions of the American Institute of Electrical Engineers. Part III: Power Apparatus and Systems*, vol. 72, no. 2, pp. 1323–1336, 1953.
- [15] R. M. Mathur and R. K. Varma, *Thyristor-based FACTS controllers for electrical transmission systems*. John Wiley & Sons, 2002.

-
- [16] M. G. Kashani, S. Babaei, and S. Bhattacharya, "Svc and statcom application in electric arc furnace efficiency improvement," in *Power Electronics for Distributed Generation Systems (PEDG), 2013 4th IEEE International Symposium on*, pp. 1–7, IEEE, 2013.
- [17] N. G. Hingorani, L. Gyugyi, and M. El-Hawary, *Understanding FACTS: concepts and technology of flexible AC transmission systems*, vol. 1. IEEE press New York, 2000.
- [18] R. Mallwitz and B. Engel, "Solar power inverters," in *Integrated Power Electronics Systems (CIPS), 2010 6th International Conference on*, pp. 1–7, IEEE, 2010.
- [19] S. Hosseini and A. Ajami, "Transient stability enhancement of ac transmission system using statcom," in *TENCON'02. Proceedings. 2002 IEEE Region 10 Conference on Computers, Communications, Control and Power Engineering*, vol. 3, pp. 1809–1812, IEEE, 2002.
- [20] V. Akhmatov, H. Knudsen, M. Bruntt, A. H. Nielsen, J. K. Pedersen, and N. K. Poulsen, "A dynamic stability limit of grid connected induction generators," in *IASTED International Conference on Power and Energy Systems: September*, pp. 235–244, 2000.
- [21] L. Holdsworth, N. Jenkins, and G. Strbac, "Electrical stability of large, offshore wind farms," in *AC-DC Power Transmission, 2001. Seventh International Conference on (Conf. Publ. No. 485)*, pp. 156–161, IET, 2001.
- [22] M. G. G. Titus, "Reactive power compensation using statcom for single phase distribution system," *Circuit, Power and Computing Technologies (IC-CPCT)*, 2015.
- [23] K. Suja and I. J. Raglend, "Power quality improvement in grid connected wind energy system using statcom," in *Computing, Electronics and Electrical Technologies (ICCEET), 2012 International Conference on*, pp. 259–266, IEEE, 2012.

-
- [24] L. Xu, L. Yao, and C. Sasse, "Comparison of using svc and statcom for wind farm integration," in *Power System Technology, 2006. PowerCon 2006. International Conference on*, pp. 1–7, IEEE, 2006.
- [25] J. O. Tande and K. Uhlen, "Wind turbines in weak grids-constraints and solutions," in *IEE CONFERENCE PUBLICATION*, vol. 4, pp. 4–16, IET, 2001.
- [26] G. Gueth, P. Enstedt, A. Rey, and R. Menzies, "Individual phase control of a static compensator for load compensation and voltage balancing and regulation," *IEEE Transactions on Power Systems*, vol. 2, no. 4, pp. 898–905, 1987.
- [27] B. Singh, S. Murthy, and R. S. R. Chilipi, "Statcom-based controller for a three-phase seig feeding single-phase loads," *IEEE transactions on energy conversion*, vol. 29, no. 2, pp. 320–331, 2014.
- [28] M.-M. Mac Low, R. S. Klessen, A. Burkert, and M. D. Smith, "Kinetic energy decay rates of supersonic and super-alfvénic turbulence in star-forming clouds," *Physical Review Letters*, vol. 80, no. 13, p. 2754, 1998.